

AAW-AS(BS) / AAT(M)系列

90度精密減速機

90 Degree Precision Speed Reducer

多種輸出軸型式、減速比: 1:2~1:500

Multiple Output Shaft Type Reduction Ratio 1:2-1:500

適用之伺服馬達容量: 0.1kw~45kw

Applicable Servo Motor Capacity : 0.1kw-45kw



大型中空旋轉法蘭:適用於大負荷場合。
TFT-LCD 面板翻轉、旋轉機構、機械手臂底座
旋轉、擺臂旋轉、分度旋轉...等機構。

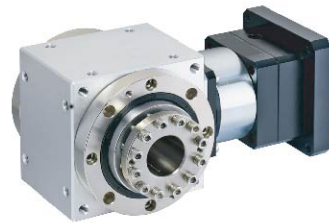

中空軸迫緊環:適用於大負荷場合。
滾輪機構、凸輪機構、輸送搬運...等機構。



出口軸型:適用於大負荷場合。
聯軸機構、皮帶輸送...等機構。



螺桿減速機:適用於直線運動場合。
垂直、水平之直線運動...等機構。

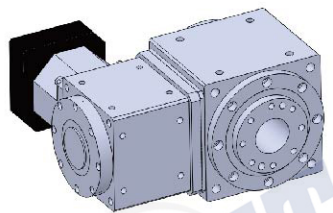

中空旋轉平台:適用於大負荷場合。
TFT-LCD 面板翻轉、分度盤機構...等機構



转向器

AAW-AS(BS) / AAT(M)系列-性能表:

Performance table

規格 Specification	段數 Stage	減速比 (i) Ratio	AAW080AS AAW110AS AAW135AS AAW165AS AAW165BS AAW200AS AAW200BS AAW320AS AAW320BS											
			AAW070AS	AAW080AS	AAW110AS	AAW135AS	AAW165AS	AAW165BS	AAW200AS	AAW200BS	AAW320AS	AAW320BS		
額定輸出 轉距 (Nm) Rated Output Torque	一段 1-stage L1	1/2,1/3,1/5,1/10	30	80	250	450	800	2000	3500					
		1/6		80	200	400	280	700	600	1500	1000	3500	2000	
		1/8		85	250	450	320	800	660	1850	1100	4000	2300	
		1/10		85	250	450	320	800	660	1850	1100	4000	2300	
		1/12		80	225	435	320	750	660	1850	1100		2300	
		1/14		80	215	425	280	750	600	1750	1000	3500	2200	
		1/16		80	210	415	270	700	600	1700	1000			
		1/20	30	70	200	400	240	700	460	1650	900	3000	1900	
		1/30	30	80	200	400	280	700	600	1500	1000	3500	2000	
		1/32		85	250	450	320	800	660	1850	1100	4000	2300	
	1/40	30	85	250	450	320	800	660	1850	1100	4000	2300		
	1/50	30	85	250	450	320	800	660	1850	1100	4000	2300		
	1/56		85	250	450	320	800	660	1850	1100	3500	2300		
	1/60		80	200	400	280	700	600	1500	1000	3500	2000		
	1/70	30	85	250	450	320	800	660	1850	1100	3500	2200		
	1/80		85	250	450	320	800	660	1850	1100	3500	2300		
	1/100	30	85	250	450	320	800	660	1850	1100	3500	2300		
	1/120		80	225	435	290	750	630	1750	1050		2200		
	1/140		80	215	425	280	750	630	1750	1000	3200	2100		
	1/160		80	210	415	270	700	600	1700	950				
1/200	30	70	200	400	240	700	460	1700	900	3000	1900			
最大輸出 轉距 (Nm) Max Output Torque	L1, L2	3~100	2.5倍額定輸出轉距 (Nm) 2.5 Times of Rated Output Torque											
輸入轉速 (rpm) Input Speed	L1, L2	3~100	3000	3000	3000	3000	3000	3000	3000	3000	3000	3000		
標準背隙 (arc-min) Standard Backlash	L1	3~10	≤5	≤5	≤5	≤5	≤5	≤5	≤5	≤5	≤5	≤5		
	L2	12~100	≤8	≤8	≤8	≤8	≤8	≤8	≤8	≤8	≤8	≤8		
精密背隙 B2(arc-min) Precision Backlash	L1	3~10	≤3	≤3	≤3	≤3	≤3	≤3	≤3	≤3	≤3	≤3		
	L2	12~100	≤4	≤4	≤4	≤4	≤4	≤4	≤4	≤4	≤4	≤4		
精密背隙 B1(arc-min) Precision Backlash	L1	3~10	≤2	≤2	≤2	≤2	≤2	≤2	≤2	≤2	≤2	≤2		
	L2	12~100	≤3	≤3	≤3	≤3	≤3	≤3	≤3	≤3	≤3	≤3		
精密背隙 B0(arc-min) Precision Backlash	L1	3~10	≤1	≤1	≤1	≤1	≤1	≤1	≤1	≤1	≤1	≤1		
	L1	3~10	≤2	≤2	≤2	≤2	≤2	≤2	≤2	≤2	≤2	≤2		
容許徑向力 (N) Permissible Radial Force	L1, L2	3~100	2800	3900	5500	9800	9800	16500	16500	24100	24100	32600		
容許軸向力 (N) Permissible Axial Force	L1, L2	3~100	2800	3900	5500	9800	9800	16500	16500	24100	24100	32600		
效率 (%) Efficiency	L1	3~10	90%											
	L2	12~100	85%											
重量 (kg) Weight	L1	3~10	2.5	4.3	7.8	20.8	15.5	35.5	28.5	55	40.5	300	270	
	L2	12~100	3.8	6.3	9.2	24.3	18.2	40.5	31.2	65.5	48.5	330	290	
使用溫度 (°C) Operating Temperature	L1, L2	3~100	-10°C~+80°C											
潤滑油 Lubricant	L1, L2	3~100	全合成潤滑油 (COMPLEX HV2) Fully Synthetic Grease											
安裝方向 Installation Direction	L1, L2	3~100	任意方向 Any Installation Direction											
噪音值 (db) Noise Level	L1, L2	3~100	≤65	≤68	≤68	≤68	≤68	≤70	≤70	≤72	≤72	≤72		

*1/2, 入力轉速需 ≤2000 RPM以內.

*1/3, 入力轉速需 ≤3000 RPM以內.

*入力軸與法蘭詳細尺寸C1~C7,如頁數 57P

型號說明 Model Description

AAW系列: AAW070AS~AAW320AS(BS)



AAW080AS — L1 — 20 — RF — S1 — B1 — Y

段數 Stages
L1(一段比數)
L2(二段比數)

伺服馬達記號: S1~S11
*無記號需提供:
伺服電機廠牌/規格

無記號:
代表標準型
特殊記號:
輸入端與輸出
端尺寸依客戶
指定製作。

AAW070AS
AAW080AS
AAW110AS
AAW135AS(BS)
AAW165AS(BS)
AAW200AS(BS)
AAW320AS(BS)

輸出軸型式: Output shaft type
P: 單實心出力軸
2P: 雙實心出力軸
CR: 中空軸帶鍵槽
RF: 中空軸旋轉法蘭
RF-K: 中空軸旋轉法蘭+鍵槽
RFHP: 中空軸+錐形迫緊環
HR: 中空旋轉平台
BS: 滾珠螺桿型

背隙等級 (AAW070AS~320AS)
無記號: 代表標準背隙
L1 ≤ 5 弧分 L2 ≤ 8 弧分
精密背隙 B1
L1 ≤ 2 弧分 L2 ≤ 3 弧分
精密背隙 B2
L1 ≤ 3 弧分 L2 ≤ 4 弧分
*特殊型: B0 超精密背隙
(L1 ≤ 1 弧分 L2 ≤ 2 弧分)

減速機比數 Ratio of Reducer: AAW070AS~AAW320AS(BS)
L1(一段比數): 2, 3, 5, 6, 8, 9, 10, 12, 15, 16, 18, 20, 21, 24, 30
L2(二段比數): 24, 32, 36, 40, 42, 45, 48, 50, 56, 60, 63, 70, 75, 80, 84, 90, 100, 105, 120, 140, 150, 160, 180, 200, 210, 240, 300
P. S: AAW070AS(1/3, 1/5, 1/10, 1/15, 1/20, 1/25, 1/30, 1/40, 1/50, 1/70, 1/100)

型號說明 Model Description

AAT系列: AAT(M)070AS~AAT(M)320AS

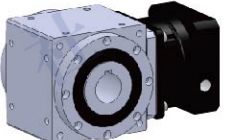

AAT080AS — 2 — P — L — S

減速比: Reduction Ratio
2, 3, 5, 7, 10
*開發中減速比: 5, 7, 10

輸出軸型式: Output shaft type
P: 單出力軸 2P: 雙出力軸 CR: 中空軸有鍵
RF: 中空旋轉法蘭
RFHP: 中空軸迫緊環
*特殊型 RFC: 中軸軸夾緊式帶鍵槽

入力尺寸記號:
S1~S11: 入力尺寸記號
註:
1. 無記號需註記伺服
電機廠牌規格
2. RT 無此記號

輸入軸與輸出軸方向:
無記號: CR
L: 左旋轉(入力右轉-出力左轉)
R: 右旋轉(入力右轉-出力右轉)

減速機型號: Reducer Model
AAT080AS, AAT110AS, AAT135AS, AAT165AS, AAT200BS
AATM070AS, AATM080AS, AATM110AS, AATM135AS, AATM165AS, AATM200BS, AATM320AS
AATM080AS-2AX, AATM110AS-2AX, AATM135AS-2AX, AATM165AS-2AX, AATM200BS-2AX

AAW-A(B)S系列-RF 大中空軸旋轉法蘭型式

Big Hollow Shaft Rotary Flange Type

*AAW070AS~~AAW320AS:減速比Ratio(1/2~~1/500)

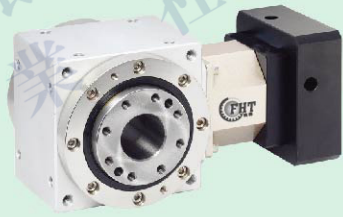

外形尺寸圖 Dimensions:

Unit:mm

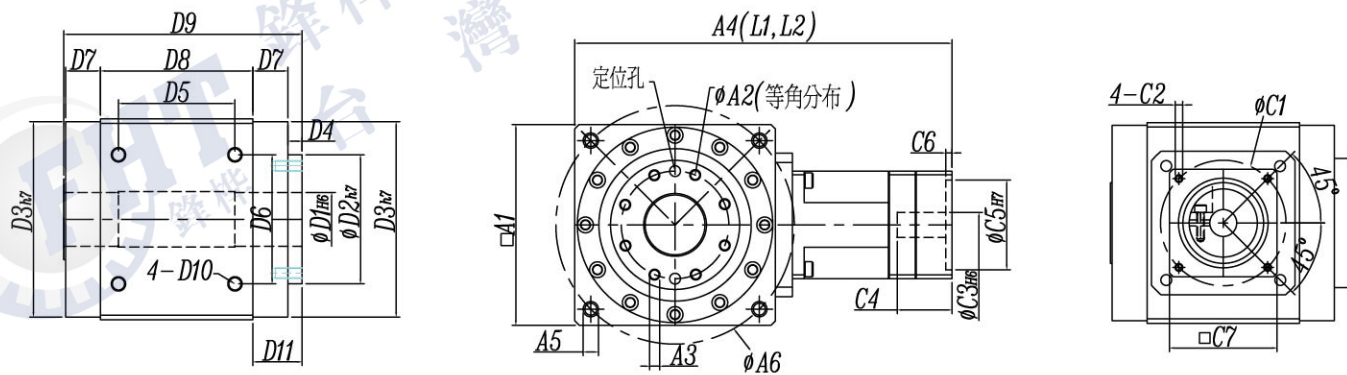

P.S:A6(可選擇通孔)

Unit:mm

規格表 Specifications:

規格	AAW070AS	AAW080AS	AAW110AS	AAW135AS	AAW135BS	AAW165AS	AAW165BS	AAW200AS	AAW200BS	AAW320AS	AAW320BS
A1	70	80	110	138	135	168	165	200	200	320	320
A2	30	36	50	70	70	95	95	124	124	193	193
A3	6-M5-10L	8-M5-10L	8-M5-15L	8-M8-15L	8-M8-15L	8-M8-15L	8-M8-15L	12-M8-15L	12-M8-15L	12-M14-25L	12-M14-18L
A4 (L1單段)	160/168	175/167	226/224	303/290	252/250	359/343	334/321	397/413	423/407	671	539
A4 (L2雙段)	183/199	206/190	268/255	362/331	290/277	434/389	393/356	487/464	469/424	741	590
A5	4-M5-10L	4-M6-12L	4-M8-15L	4-M10-18L	4-M10-18L	4-M12-20L	4-M12-20L	4-M16-30L	4-M16-30L	4-M20-35L	4-M20-30L
A6	75	93	130	160	160	193	193	240	240	380	380
D1	16	20	30	40	40	55	55	80	80	110	110
D2	38	45	65	85	85	110	110	140	140	220	220
D3	60	78	106	133	133	163	163	195	195	306	306
D4	8.25	7	9.5	9.5	9.5	17	17	22	22	17.5	17.5
D5	42.43	49.5	68	86	78	106	100	141	129	170	170
D6	42.43	49.5	65	83	83	105	105	130	130	220	220
D7	6.25	13	15	10	19	13	19	8.5	22	30	30
D8	70	67	90	120	102	142	130	182	155	236	236
D9	92.25	102	131.5	151.5	151.5	187	187	223	223	316.5	316.5
D10	4-M5-10L	4-M6-12L	4-M8-15L	4-M10-18L	4-M10-18L	4-M14-16L	4-M14-16L	4-M14-20L	4-M14-20L	6-M20-35L	6-M20-35L
D11	14.5	20	24.5	19.5	28.5	30	36	30.5	44	47.5	47.5
C1	≤70	≤90	≤145	≤200	≤145	≤215	≤200	≤215	≤215	≤400	≤265
C2	≤M5	≤M6	≤M8	≤M12	≤M8	≤M12	≤M12	≤M12	≤M12	≤M18	≤M14
C3	≤14	≤19	≤24	≤35	≤24	≤42	≤35	≤42	≤42	≤60	≤55
C4	≤31	≤41	≤62	≤80	≤62	≤116	≤80	≤116	≤116	≤145	≤116
C5	≤50	≤70	≤110	≤114.3	≤110	≤180	≤114.3	≤180	≤180	≤300	≤230
C6	≤3.5	≤3.5	≤7	≤7	≤7	≤7	≤7	≤7	≤7	≤7	≤7
C7	≤62	≤80	≤120	≤180	≤120	≤200	≤180	≤200	≤200	≤350	≤250

*入力軸與法蘭詳細尺寸C1~C7,如頁數57P

AAW-A(B)S系列-RFHP 大中空軸迫緊環型式

Big Hollow Shaft Tight Ring Type

*AAW070AS~~AAW320A(B)S:減速比Ratio(1/2~~1/500)



外形尺寸圖 Dimensions:

Unit:mm

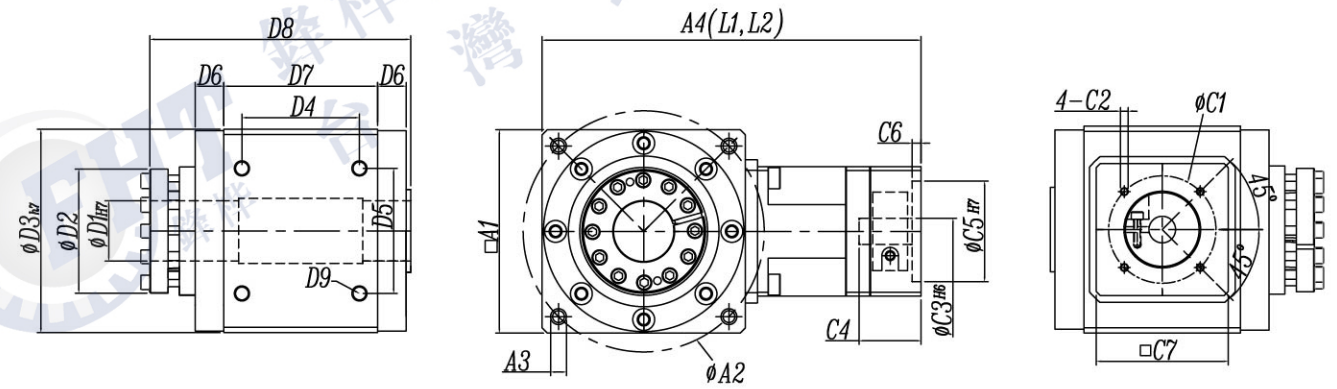

P.S:A2(可選擇通孔)

Unit:mm

規格表 Specifications:

規格	AAW080AS	AAW110AS	AAW135AS	AAW135BS	AAW165AS	AAW165BS	AAW200AS	AAW200BS	AAW320AS	AAW320BS
A1	80	110	138	135	168	165	200	200	320	320
A2	93	130	160	160	193	193	240	240	380	380
A3	4-M6-12L	4-M8-15L	4-M10-18L	4-M10-18L	4-M12-20L	4-M12-20L	4-M16-30L	4-M16-30L	4-M20-35L	4-M20-35L
A4 (L1單段)	175/167	226/224	303/290	252/250	359/343	334/321	397/413	423/407	671	539
A4 (L2雙段)	206/190	268/255	362/331	290/277	434/389	393/356	487/464	469/424	741	590
D1	20	30	40	40	55	55	65	65	105	105
D2	45	65	85	85	110	110	140	140	220	220
D3	78	106	133	133	163	163	195	195	306	306
D4	49.5	68	86	78	106	100	141	129	175	175
D5	49.5	65	83	83	105	105	130	130	220	220
D6	13	15	10	19	13	19	8.5	22	30	30
D7	67	90	120	102	142	130	182	155	236	236
D8	113	144.5	173.5	173.5	206	206	243.5	243.5	337	337
D9	4-M6-12L	4-M8-15L	4-M10-18L	4-M10-18L	4-M14-16L	4-M14-16L	4-M14-20L	4-M14-20L	6-M20-30L	6-M20-30L
C1	≤90	≤145	≤200	≤145	≤215	≤200	≤215	≤215	≤400	≤265
C2	≤M6	≤M8	≤M12	≤M8	≤M12	≤M12	≤M12	≤M12	≤M18	≤M14
C3	≤19	≤24	≤35	≤24	≤42	≤35	≤42	≤42	≤60	≤55
C4	≤41	≤62	≤80	≤62	≤116	≤80	≤116	≤116	≤145	≤116
C5	≤70	≤110	≤114.3	≤110	≤180	≤114.3	≤180	≤180	≤300	≤230
C6	≤3.5	≤7	≤7	≤7	≤7	≤7	≤7	≤7	≤7	≤7
C7	≤80	≤120	≤180	≤120	≤200	≤180	≤200	≤200	≤350	≤250

*入力軸與法蘭詳細尺寸C1~C7,如頁數57P

AAW-AS(BS) / AAT(M)系列

入力端詳細尺寸圖 Detailed Sizes Diagram of Input End

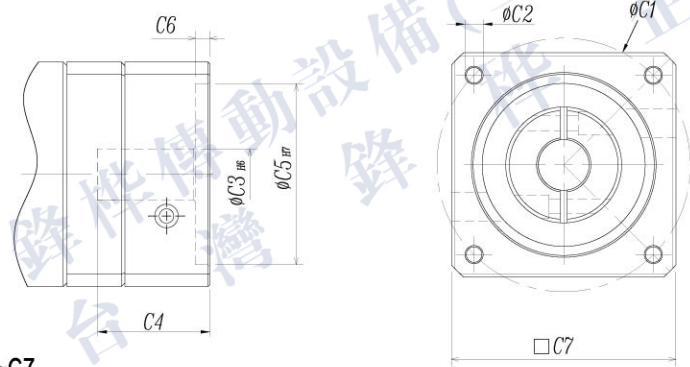

*入力軸與法蘭詳細尺寸C1~C7.

*馬達記號是指不同廠牌的入力端尺寸.

*特製品:可依客戶指定製作入力法蘭尺寸.

型號	AAW070AS/AATM080AS/AAW080AS										AATM110AS/AAW110AS/AAW135BS										
馬達記號	S1	S2	S3	S4	S5	S6	S7	S8	S9	S10	S1	S2	S3	S4	S5	S6	S7	S8	S9	S10	S11
尺寸 C1	45	46	70	70	70	90	90	66.7	70	70	70	70	70	90	90	90	90	100	145	145	145
C2	M3	M4	M4	M4	M5	M5	M6	M4	M4	M4	M5	M5	M6	M6	M6	M6	M6	M8	M8	M8	M8
C3 H6	8	8	11	14	14	14	14	6.35	11	14	14	14	14	14	16	19	16	19	22	24	24
C4	31	31	31	31	31	31	31	31	41	41	41	41	41	41	41	41	41	58	58	58	58
C5 H7	30	30	50	50	50	70	70	38.1	50	50	50	70	70	70	70	80	110	110	110	110	110
C6	3.5	3.5	3.5	3.5	3.5	3.5	3.5	3.5	5	5	5	5	5	5	5	5	5	5	5	5	5
C7	62	62	62	62	62	80	80	62	90	90	90	90	90	90	90	90	90	130	130	130	130

型號	AATM135AS/AAW135AS/AAW165BS								AATM165AS/AAW165AS/AATM200BS/AAW200BS									
馬達記號	S1	S2	S3	S4	S5	S6	S7	S8	S9	S10	S1	S2	S3	S4	S5	S6	S7	S8
尺寸 C1	90	90	100	115	115	130	145	145	145	145	115	115	145	145	145	145	200	165
C2	M6	M6	M6	M6	M8	M8	M8	M8	M8	M8	M6	M8	M8	M8	M8	M8	M12	M10
C3 H6	16	19	16	24	24	19	19	22	24	28	24	24	19	22	24	28	35	32
C4	54	54	54	54	54	62	62	62	62	63	60	60	65	65	65	65	81	65
C5 H7	70	70	80	95	95	110	110	110	110	110	95	95	110	110	110	110	114.3	130
C6	7	7	7	7	7	7	7	7	7	7	7	7	7	7	7	7	7	7
C7	120	120	120	120	120	120	120	120	120	120	142	142	142	142	142	142	176	142

型號	AAW200AS/AAW320BS										AAW320AS						
馬達記號	S1	S2	S3	S4	S5	S6	S7	S8	S9	S10	S1	S2	S3	S4	S5	S6	S7
尺寸 C1	145	145	145	115	200	200	165	215	235	235	200	200	215	215	235	235	265
C2	M8	M8	M8	M6	M12	M12	M10	M12	M12	M12	M10	M12	M12	M12	M12	M12	M12
C3 H6	19	22	24	28	35	42	32	38	42	55	55	35	42	38	42	42	55
C4	75	75	75	75	81	81	81	116	116	116	116	116	116	116	116	116	116
C5 H7	110	110	110	110	114.3	114.3	130	180	200	200	230	114.3	114.3	180	180	200	230
C6	10	10	10	10	10	10	10	10	10	10	10	10	10	10	10	10	10
C7	180	180	180	180	180	180	180	192	220	220	250	220	220	220	220	200	250

*入力軸與法蘭詳細尺寸C1~C7,如頁數57P

減速機與馬達安裝說明書

Installation Instruction of Reducer & Motor

Step 1:
確認馬達減速機規格，並將馬達及減速機之安裝面擦拭乾淨。

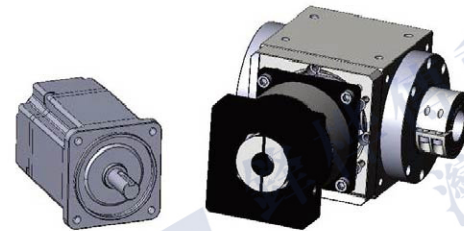

Step 2:
取下馬達上原先之鍵。

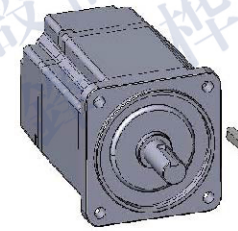

Step 3:
如有需要請加上軸襯套。

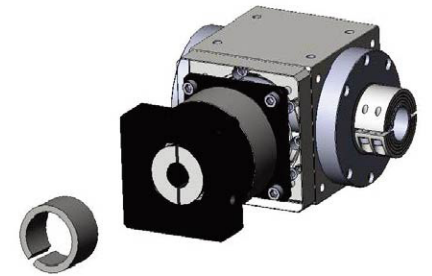

Step 4:
直立式的裝入馬達，以螺絲扭力值表(表一)建議扭力值之5%，依1~4的順序，用扳手將附墊片之螺絲輕輕鎖上。

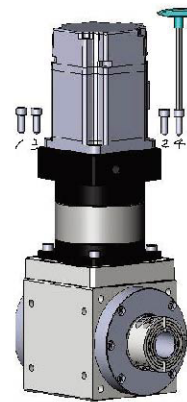

Step 5:
將馬達與減速機直立擺設，參照表二建議之扭力值，以扭力扳手將埋栓鎖緊。

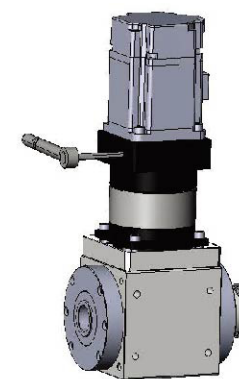

Step 6:
將馬達與減速機直立擺設，以螺絲扭力表(表一)建議之扭力值，依1~4的順序，用扭力扳手將螺絲鎖緊。

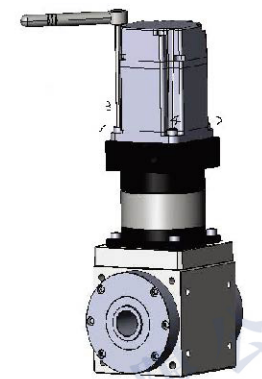

螺絲尺寸	馬達鎖緊螺絲扭力建議表						
	六角頭尺寸 [mm]	強度 8.8 螺絲之鎖緊力		強度 10.9 螺絲之鎖緊力		強度 12.9 螺絲之鎖緊力	
		[Nm]	[In-lbs]	[Nm]	[In-lbs]	[Nm]	[In-lbs]
M3×0.5P	25	1.3	12	1.8	16	2.1	19
M4×0.7P	3	3	27	4.1	37	4.9	44
M5×0.8P	4	6.1	55	8.2	73	9.8	87
M6×1P	5	11	98	14	124	17	151
M8×1.25P	6	25	222	34	302	41	364
M10×1.5P	8	49	434	67	594	80	709
M12×1.75P	10	85	753	116	1028	139	1232
M14×2P	12	137	1214	186	1648	223	1976
M16×2P	14	210	1860	286	2534	343	3038