

* 臺灣鋒樺企業行星減速器產品

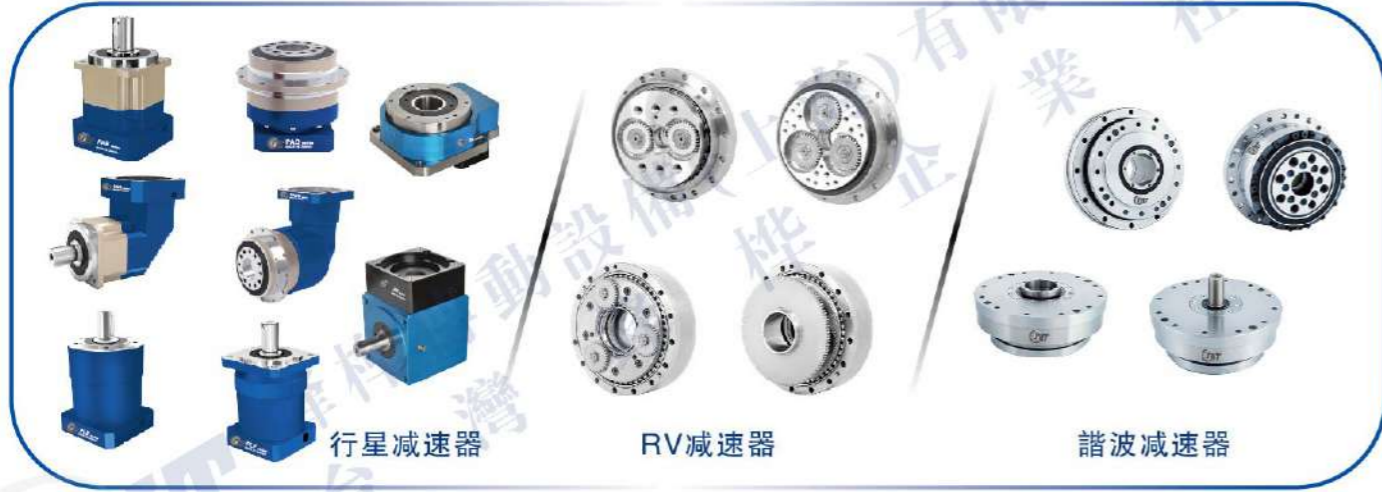

行星減速器

RV減速器

諧波減速器



鋒樺傳動設備(上海)有限公司

90度伺服減速器

臺灣鋒樺企業社



台灣鋒樺企業社
鋒樺傳動設備(上海)有限公司

90度直角
伺服減速器



AT通用型
AT065-AT280系列
ATF065-ATF280系列



PAW標準型
PT070A-PT180B系列
PAW055A-PAW180A(B)系列



AAW精密型
AAT(M)070AS-AAT(M)320AS系列
AAW070AS-AAW320AS(BS)系列



公司簡介 Company Introduction

臺灣鋒樺企業社,由專業製造齒輪工廠開始發展,工廠同仁及研發團隊具有二十幾年齒輪製造研發及設計經驗,工廠于民國93年成立行星減速器事業部,同年與日本NDK公司技術合作,優化完善行星齒輪減速機系列產品綫設計及製造工藝,所生產的系列精密減速器具低背隙(5~8arcmin)、低噪音(60dAB)、高效率(>=95%)之三大特性。其可以搭配任意伺服工廠所生產伺服馬達、步進馬達,高精行星減速器具有降低轉速、高轉矩化、增加馬達轉子慣性,提高剛性、縮短啓動與停止定位時間,馬達功率小型化,同時提高慣性負載的安定性與降低振動的特點,為提升產品升級,適應高精度等級產品適用範疇。

工廠于民國99年全系列上綫-高精度斜齒行星減速器,具有超低背隙(1~3arcmin)精度等級,新開發產品可直接替換德國和日本尺寸,產品系列全部齊全,尺寸和精度和日系、德系減速器完全匹配,產品廣泛運用工具機(龍門機床),激光切割機,木工雕刻機,全伺服紙巾機械,精度凹凸版印刷機,精密塗布機,伺服彎管機,數控彈簧機等自動化程度較高設備!

工廠早期就在中國大陸設立服務所,主推國內市場,成立-鋒樺傳動設備(上海)有限公司,匹配大量產品庫存,協同伺服電機廠家及系統集成商,扎根大陸市場,立志通過優良的產品服務于國內自動化行業和機器人領域,為中國機器人事業和工業4.0方向服務。



生產檢測中心
Production testing center



90度型式精密減速機剖面圖與簡介:

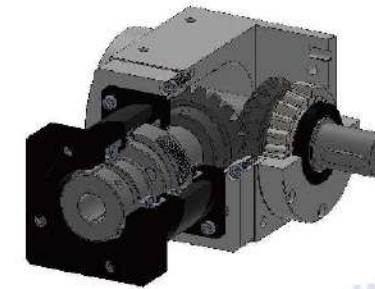

高強度:高精度螺旋傘齒輪,採用鎳鉻合金鋼SCM415 HRC60度。
高效率:高效率行星機構和精密螺旋傘齒輪之組合。
高剛性:本齒箱有優良的剛性結構,採用雙錐形軸承支撐,對於輸出端負載變化大的場合特別適合。
多樣化:輸出軸種類多樣化,有單出力軸型、雙出力軸型、中空軸型、中空法蘭型、中空軸錐形迫緊型、螺桿直線型、螺牙直線型。

減速比:單段1:3~1:10 雙段1:12~1:100
體積小、省空間:框號55MM~220MM
輸出扭矩:15Nm~1600Nm,螺旋傘齒輪模數M1.0~M6.0
安裝容易:5個面方向皆可安裝。
適用容量:50W~15KW
專利設計:本齒箱已申請通過多種專利。



低噪音內螺旋齒輪設計

高精度
客制化服務

創新研發
品質保證

專業加工
二十年經驗

产品应用行业 Product Application Industry

半导体液晶制造设备、机器人、机床等需要精密运动控制的前沿领域得到广泛应用。
Semiconductor liquid crystal manufacturing equipment, robots, machine tools, and other frontiers of precision motion control are widely used.

<p>机器人的行走轴(齿条&小齿轮) The walking shaft of a robot (rack and pinion)</p> <p>FH精密减速机</p>	<p>机床的龙门机器人 Gantry robot of machine tool</p> <p>齿条&小齿轮 链条 皮带 FH精密减速机</p>	<p>水平多关节机器人 Horizontal multi-joint robot</p> <p>FH精密减速机</p>	<p>晶圆搬运机器人 Wafer handling robot</p> <p>FH精密减速机</p>
<p>冲压设备(铆接) Stamping equipment (riveting)</p> <p>FH精密减速机</p>	<p>弯管机 Pipe bending machine</p> <p>FH精密减速机</p>	<p>注塑成型取出机器人 Injection mold taken-out robot</p> <p>直驱机械臂 FH精密减速机</p>	<p>机床的转塔刀架旋转 Rotary tower knife frame rotation of machine tool</p> <p>FH精密减速机</p>
<p>机床的XY轴 The XY axis of machine tool</p> <p>齿条&小齿轮 FH精密减速机</p>	<p>分度工作台驱动 Indexing table drive</p> <p>FH精密减速机</p>	<p>涂抹用辊驱动 Roller drive for daubing use</p> <p>FH精密减速机</p>	<p>装载机用滑轮 Pulley for loader use</p> <p>FH精密减速机</p>
<p>轴输入型皮带驱动 Shaft input belt drive</p> <p>FH精密减速机</p>	<p>液晶玻璃基板搬运机器人 Liquid crystal glass substrate handling robot</p> <p>FH精密减速机</p>	<p>拉力试验机 Tensile testing machine</p> <p>FH精密减速机</p>	<p>顶棚行走式搬运车 Roof walking van</p> <p>车轮 轨道 FH精密减速机</p>

<p>无人搬运车 Unmanned vehicle</p> <p>车轮 FH精密减速机</p>	<p>高速工作用机器人 Robot for working in height</p> <p>FH精密减速机</p>	<p>卷起 Roll up</p> <p>FH精密减速机</p>
<p>旋转 Rotate</p> <p>FH精密减速机</p>	<p>搬送 Transport</p> <p>FH精密减速机</p>	<p>角度(定位)控制 Angle (positioning) control</p> <p>FH精密减速机</p>
<p>两轴控制(XY工作台) Two axis control (XY workbench)</p> <p>FH精密减速机</p>	<p>辊驱动 Roller drive</p> <p>FH精密减速机</p>	
<p>弯管机 Pipe bending machine</p> <p>FH精密减速机</p>	<p>冲压(铆接) Punching (riveting)</p> <p>FH精密减速机</p>	<p>印刷电路板检查装置 Printed circuit board inspection device</p> <p>FH精密减速机</p>

產品目錄 CONTENTS

AT

軸輸入轉向器
Shaft Input Steering Gearbox



01-08

AT-F

法蘭輸入90度減速器
Flange Input 90 Degree Reducer



09-24

PAW-A(B)

標準型90度減速機
Standard Type 90 Degree Reducer



25-32

PT

標準型轉向器
Standard Type Steering Gearbox



33-37

AAW-AS(BS)

精密型90度減速機
Precision Type 90 Degree Reducer



39-47

AAW-BS

90度螺桿減速機
90 Degree Screw Reducer



48

AATM

精密型轉向器
Precision Type Steering Gearbox



49-53

AAT

精密型轉向器
Precision Type Steering Gearbox



54-56

AATM-2AX

90度兩軸轉向器
90 Degree Two Shaft Steering Gearbox

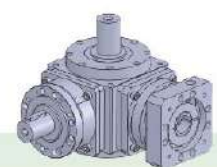

59-60

減速機的訂購 Purchase of Reducer



AT065 - L - 1 - S1

減速機型號：Reducer Model
AT065, AT075, AT090, AT110, AT140,
AT170, AT210, AT240, AT280

減速比：Reduction Ratio
單節：1, 1.5, 2, 3, 4, 5

減速機型式：Reducer Type
L / L1 / H / C / R1 / LM / RM / 4M

軸型式選擇：Selection of Shaft Type
S1: 平滑直軸 Smooth Straight Shaft
S2: 附鍵直軸 Attached Key Straight Shaft

選用範例 Selection Example：AT065-L-1-S1



AT210 - FL1 - 200 - S1 / MOTOR

減速機型號：Reducer Model
AT065, AT075, AT090, AT110, AT140,
AT170, AT210, AT240, AT280

減速比：Reduction Ratio
單節：1, 1.5, 2, 3, 4, 5
雙節：7, 10, 15, 20, 25, 35, 50
三節：75, 100, 125, 150, 200,
250, 350, 500

馬達型號：Motor Model
馬達製造商及型號
Motor Manufacture & Model

減速機型式：Reducer Types
FL / FLM1 / FLM2 / FL1 / FL1M1 / FL1M2 /
FR1 / FR1M1 / FR1M2 / FH / FHM1 / FHM2 /
FC / FCM1 / FCM2

軸型式選擇：Shaft Type Selection
S1: 平滑直軸 Smooth Straight Shaft
S2: 附鍵直軸 Attached Key Straight Shaft

選用範例 Selection Example：AT210-FL1-200-S1 / SIEMENS 1FK6 032-6AK71

AT 雙軸出軸系列

產品特點

Double Output Shaft Series Product Features

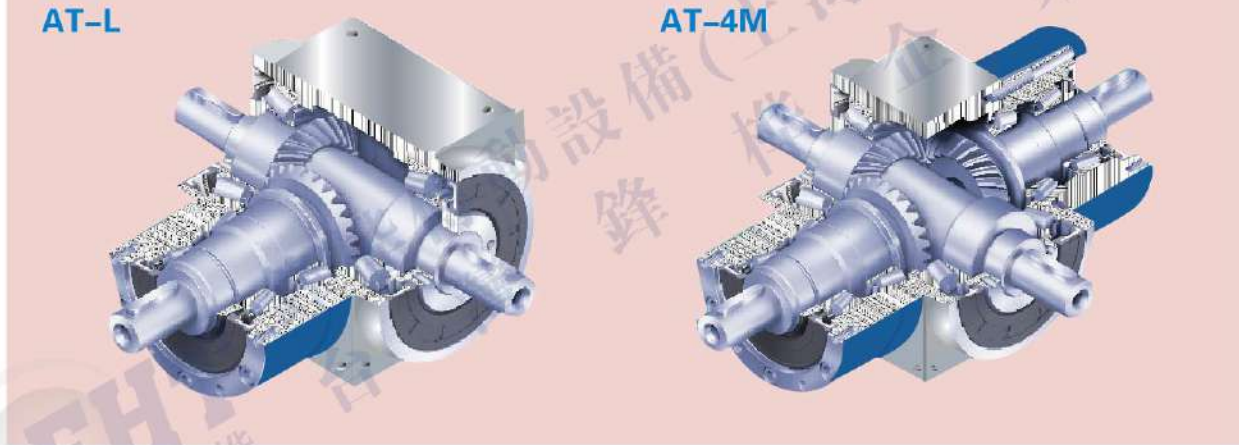

- 一體化不銹鋼本體確保最大剛性與耐蝕性，多重精密加工表面易于組裝。
Integrated stainless steel body ensures maximum rigidity and corrosion resistance. Multiple precision machined surface for easy assembly.
- 採用頂級蝸綫傘齒輪的設計軟體，經最佳化設計接觸齒面負載均一容許高扭矩輸出，齒輪採用高強度滲碳合金鋼，研磨精密度符合 DIN 5 級標準以內。
The adoption of the top spiral worm gear design software and the optimized design of contact tooth surface make the even load and allow high torque output. Gears are made of high strength carburizing alloy steel and the grinding precision is up to the standard of DIN 5 level.
- 多重不銹鋼輸出入力軸的設計可以適用於各種工業上應用的需求。
Multiple stainless steel output and input shaft design can be applied to various of industrial applications needs.
- 高精度研磨的蝸綫傘齒輪組結合最佳化設計的行星式齒輪組可以達到500:1 的減速比。
The combination of high-precision grinded worm bevel gear set and the optimized the design of planetary gear set can make the reduction speed up to 500:1.
- 高扭矩低背隙的精簡結構設計適用於精密伺服的應用。
High torque and low backlash design of the compact structure is suitable for the application of precision servo.
- 專利的油封設計，免保養無需更換潤滑油，運轉壽命長。
Patented oil seal design, maintenance-free without replacing the lubrication oil, long operating life.

重量 Weight

減速機型 Model No.		節數 Stage	比數 ¹ Ratio	AT065	AT075	AT090	AT110	AT140	AT170	AT210	AT240	AT280
L 系列 L Series	kg	1	1~5	2.6	4.2	6.8	11.6	19.8	34.8	66.2	98.1	155.7
L1 系列 L1 Series		1	1~5	2.6	4.1	6.7	11.5	19.5	34.2	65.1	96.6	153.4
H 系列 H Series		1	1~5	2.5	3.9	6.4	11.0	18.1	31.6	60.0	89.4	143.4
C 系列 C Series		1	1~5	2.8	4.2	6.9	11.4	19.6	33.7	63.3	97.9	149.1
R1 系列 R1 Series		1	1~5	2.6	4.1	6.7	11.5	19.5	34.2	65.1	96.6	153.4
LM 系列 LM Series		1	1	3.5	5.6	9.0	15.2	24.1	42.4	81.4	122.0	190.9
RM 系列 RM Series		1	1	3.5	5.6	9.0	15.2	24.1	42.4	81.4	122.0	190.9
4M 系列 4M Series		1	1	3.5	5.6	9.1	15.4	24.8	42.6	82.5	123.5	193.3

AT 雙軸出軸系列

產品規格

Double Output Shaft Series Product Specification

減速機性能資料 Files of Reducer Performance

規格 Specification	節數 Stage	比數 ¹ Ratio ²	AT065 L	AT075 L	AT090 L	AT110 L	AT140 L	AT170 L	AT210 L	AT240 L	AT280 L	
			AT065 L1	AT075 L1	AT090 L1	AT110 L1	AT140 L1	AT170 L1	AT210 L1	AT240 L1	AT280 L1	
額定輸出力矩 T_{2N} Rated Output Torque	1	1	25	45	78	150	360	585	1,300	2,150	3,200	
		1.5	25	45	78	150	360	585	1,300	2,150	3,200	
		2	24	42	68	150	330	544	1,220	2,010	3,050	
		3	18	33	54	120	270	450	1,020	1,650	2,850	
		4	13	28	48	100	224	376	860	1,410	2,300	
	5	12	25	40	85	196	320	740	1,210	2,000		
最大加速力矩 T_{2b} Max.	Nm	1	1.5倍額定輸出力矩 1.5 Times of Rated Output Torque									
最大加速輸入轉速 n_{2b} Max.	rpm	1	7,500	6,500	5,500	4,500	3,500	3,000	2,200	2,000	1,700	
背隙 ³ Backlash	arcmin	1	1~5	≤6	≤6	≤6	≤6	≤6	≤6	≤6	≤6	
容許徑向力 F_{r1b} ³ Radial 輸入軸d1 Input d1	N	1	1~5	700	950	1,450	2,100	2,700	3,800	7,800	9,600	10,500
容許徑向力 F_{r2b} ³ Radial 輸出軸d2 Output d2	N	1	1~5	900	1,100	1,700	2,700	4,800	6,600	11,500	16,000	18,000
容許軸向力 F_{t1a} ³ Axial 輸入軸d1 Input d1	N	1	1~5	350	425	725	1,050	1,350	1,900	3,900	4,800	5,250
容許軸向力 F_{t2a} ³ Axial 輸出軸d2 Output d2	N	1	1~5	450	550	850	1,350	2,400	3,300	5,750	8,500	9,000
使用壽命 Service Life	hr	1	1~5	20,000*								
效率 η Efficiency	%	1	1~5	≥98%								
使用溫度 Operating Temp	°C	1	1~5	-10°C ~ 90°C								
潤滑 Lubrication				合成潤滑油 Fully Synthetic Grease								
噪音值 ($n=1500$ rpm, 無負載) dB(A)		1	1~5	≤68	≤70	≤74	≤76	≤77	≤78	≤80	≤82	≤83

1. 減速比 ($i=N_2/N_1$)
2. 作用於輸入軸中心位置 @ n_1
3. 作用於輸出軸中心位置 @ n_2
* 連續運轉降低使用壽命二分之一。
* 背隙值為在 2% 額定力矩 T_{2N} 的扭力下所測得

減速機轉動慣量 Rotary Inertia of Reducer

規格 Specification	節數 Stage	比數 ¹ Ratio ²	AT065 L	AT075 L	AT090 L	AT110 L	AT140 L	AT170 L	AT210 L	AT240 L	AT280 L
			AT065 L1	AT075 L1	AT090 L1	AT110 L1	AT140 L1	AT170 L1	AT210 L1	AT240 L1	AT280 L1
轉動慣量 J_1 Rotary Inertia	1	1	0.51	1.30	3.16	7.70	23.57	58.99	195.40	369.34	799.12
		1.5	0.64	1.16	2.82	6.74	19.37	49.28	155.45	283.58	595.78
		2	0.44	1.11	2.70	6.31	17.75	45.35	140.24	249.74	511.76
		3	0.43	1.09	2.66	6.17	17.18	44.01	134.95	237.71	483.06
		4	0.43	1.09	2.65	6.13	17.06	43.70	133.58	234.72	476.26
	5	0.43	1.09	2.65	6.12	17.02	43.60	133.14	233.67	473.58	

AT-L系列雙軸出軸型式

Double Output Shaft Type

尺寸 (單節 1-stage, 減速比ratio i=1~5)



Unit:mm

外形尺寸圖 Dimensions:

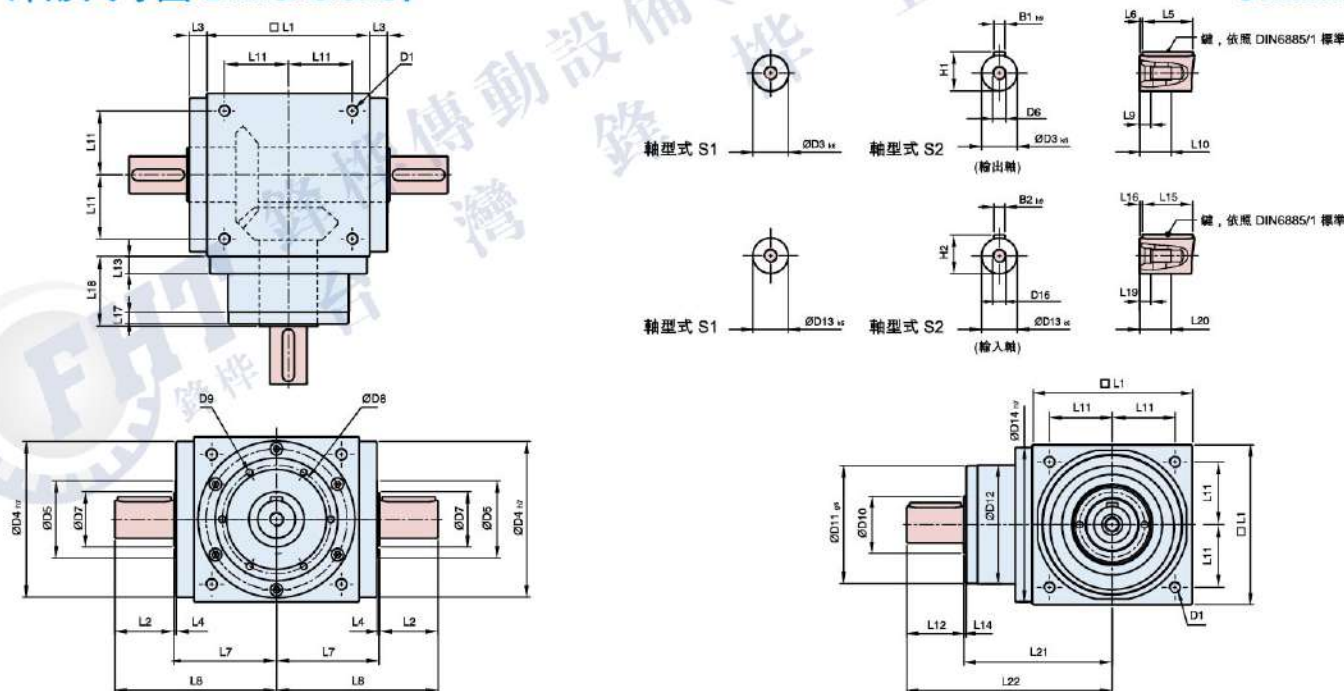

規格表 Specifications:

Unit:mm

尺寸 Sizes	AT065 L	AT075 L	AT090 L	AT110 L	AT140 L	AT170 L	AT210 L	AT240 L	AT280 L
D1	M4	M6	M6	M8	M10	M12	M16	M16	M16
D3 k8	13	16	18	22	32	40	50	55	60
D4 h7	63	73	88	108	135	165	205	235	275
D5	31	35	43	53	68	83	104	124	144
D6	M4	M5	M5	M8	M12	M16	M16	M16	M20
D7	21	22	28	33	47	55	75	85	110
D8	53	62	76	95	92	114	142	160	176
D9	4xM4xL7	4xM5xL8	4xM5xL8	6xM6xL10	6xM6xL10	6xM8xL12.5	6xM8xL12.5	6xM8xL12.5	6xM10xL15
D10	15.4	20.4	25.8	35.8	49.8	59.3	79.3	92.3	102.3
D11 g8	62.9	72.9	87	107	103	127	158	188	198
D12	62	72	86	106	104	128	160	180	200
D13 k8	13	16	18	22	32	40	50	55	60
D14 h7	63	73	88	108	135	165	205	235	275
D16	M4	M5	M5	M8	M12	M16	M16	M16	M20
L1	65	75	90	110	140	170	210	240	280
L2	19.5	30	35	40	50	60	75	85	110
L3	13	14.5	15	15	15	15	20	25	25
L4	2	2	2	2	2	2	2	2	2
L5	16	25	28	32	45	50	70	80	100
L6	2	2.5	3.5	4	2.5	5	2.5	2.5	5
L7	47.5	54	62	72	87	102	127	147	167
L8	67	84	97	112	137	162	202	232	277
L9	4.5	4.8	4.8	7.2	10	12	12	12	15
L10	10	12.5	12.5	19	28	36	36	36	42
L11	27	30	36	44	55	67	85	95	110
L12	19.5	30	35	40	50	60	75	85	110
L13	13	15	15	15	15	15	20	25	25
L14	2	2	2	2	2	2	2	2	2
L15	16	25	28	32	45	50	70	80	100
L16	2	2.5	3.5	4	2.5	5	2.5	2.5	5
L17	6	8	8	8	10	10	10	10	10
L18	43	52.5	55	60	60	70	90	105	120
L19	4.5	4.8	4.8	7.2	10	12	12	12	15
L20	10	12.5	12.5	19	28	36	36	36	42
L21	75.5	90	100	115	130	155	195	225	260
L22	95	120	135	155	180	215	270	310	370
B1 h9	5	5	6	6	10	12	14	16	18
B2 h9	5	5	6	6	10	12	14	16	18
H1	15	18	20.5	24.5	35	43	53.5	59	64
H2	15	18	20.5	24.5	35	43	53.5	59	64

AT-L1 (左) / AT-R1 (右) 系列

單邊出軸型式 Single-side Output Shaft Type

尺寸 (單節 1-stage, 減速比ratio i=1~5)



Unit:mm

外形尺寸圖 Dimensions:

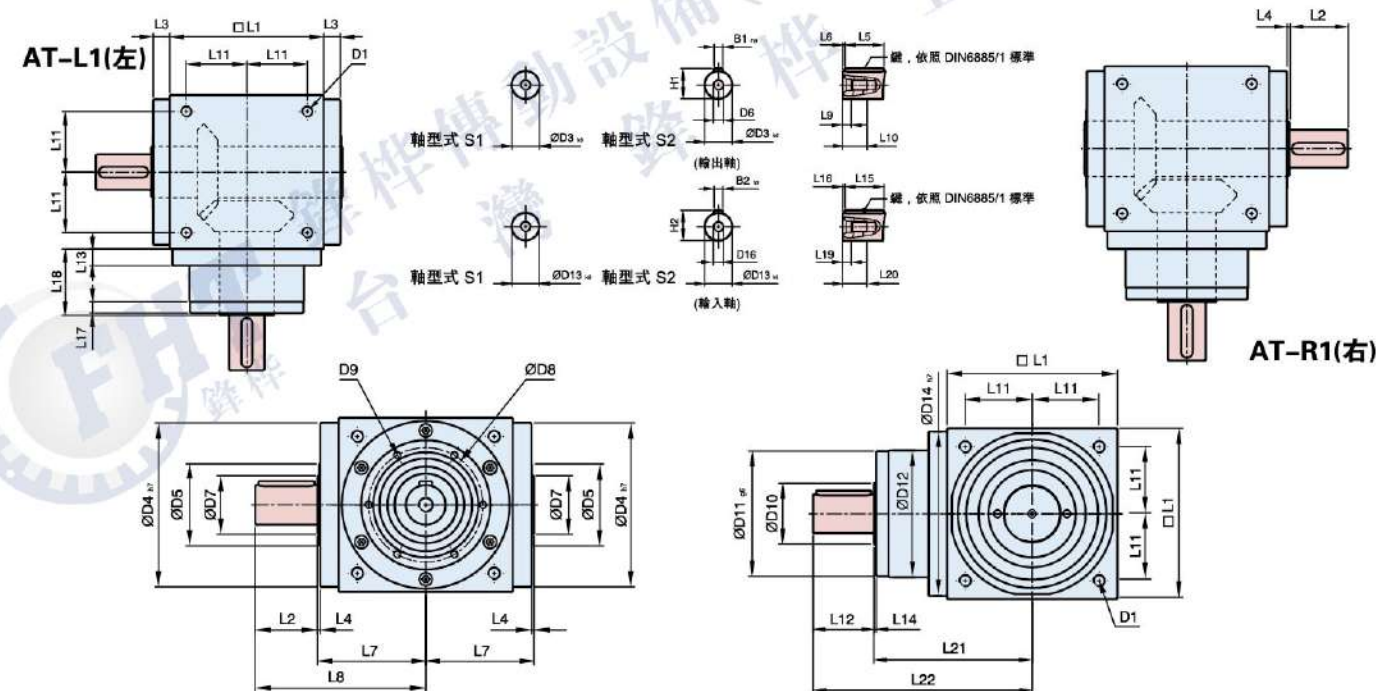

規格表 Specifications:

Unit:mm

尺寸 Sizes	AT065 L1/R1	AT075 L1/R1	AT090 L1/R1	AT110 L1/R1	AT140 L1/R1	AT170 L1/R1	AT210 L1/R1	AT240 L1/R1	AT280 L1/R1
D1	M4	M6	M6	M8	M10	M12	M16	M16	M16
D3 k8	13	16	18	22	32	40	50	55	60
D4 h7	63	73	88	108	135	165	205	235	275
D5	31	35	43	53	68	83	104	124	144
D6	M4	M5	M5	M8	M12	M16	M16	M16	M20
D7	21	22	28	33	47	55	75	85	110
D8	53	62	76	95	92	114	142	160	176
D9	4xM4xL7	4xM5xL8	4xM5xL8	6xM6xL10	6xM6xL10	6xM8xL12.5	6xM8xL12.5	6xM8xL12.5	6xM10xL15
D10	15.4	20.4	25.8	35.8	49.8	59.3	79.3	92.3	102.3
D11 g8	62.9	72.9	87	107	103	127	158	188	198
D12	62	72	86	106	104	128	160	180	200
D13 k8	13	16	18	22	32	40	50	55	60
D14 h7	63	73	88	108	135	165	205	235	275
D16	M4	M5	M5	M8	M12	M16	M16	M16	M20
L1	65	75	90	110	140	170	210	240	280
L2	19.5	30	35	40	50	60	75	85	110
L3	13	14.5	15	15	15	15	20	25	25
L4	2	2	2	2	2	2	2	2	2
L5	16	25	28	32	45	50	70	80	100
L6	2	2.5	3.5	4	2.5	5	2.5	2.5	5
L7	47.5	54	62	72	87	102	127	147	167
L8	67	84	97	112	137	162	202	232	277
L9	4.5	4.8	4.8	7.2	10	12	12	12	15
L10	10	12.5	12.5	19	28	36	36	36	42
L11	27	30	36	44	55	67	85	95	110
L12	19.5	30	35	40	50	60	75	85	110
L13	13	15	15	15	15	15	20	25	25
L14	2	2	2	2	2	2	2	2	2
L15	16	25	28	32	45	50	70	80	100
L16	2	2.5	3.5	4	2.5	5	2.5	2.5	5
L17	6	8	8	8	10	10	10	10	10
L18	43	52.5	55	60	60	70	90	105	120
L19	4.5	4.8	4.8	7.2	10	12	12	12	15
L20	10	12.5	12.5	19	28	36	36	36	42
L21	75.5	90	100	115	130	155	195	225	260
L22	95	120	135	155	180	215	270	310	370
B1 h9	5	5	6	6	10	12	14	16	18
B2 h9	5	5	6	6	10	12	14	16	18
H1	15	18	20.5	24.5	35	43	53.5	59	64
H2	15	18	20.5	24.5	35	43	53.5	59	64

AT-H系列孔輸入型式

Hole Input Type

尺寸 (單節1-stage, 減速比ratio i=1~5)



外形尺寸圖 Dimensions:

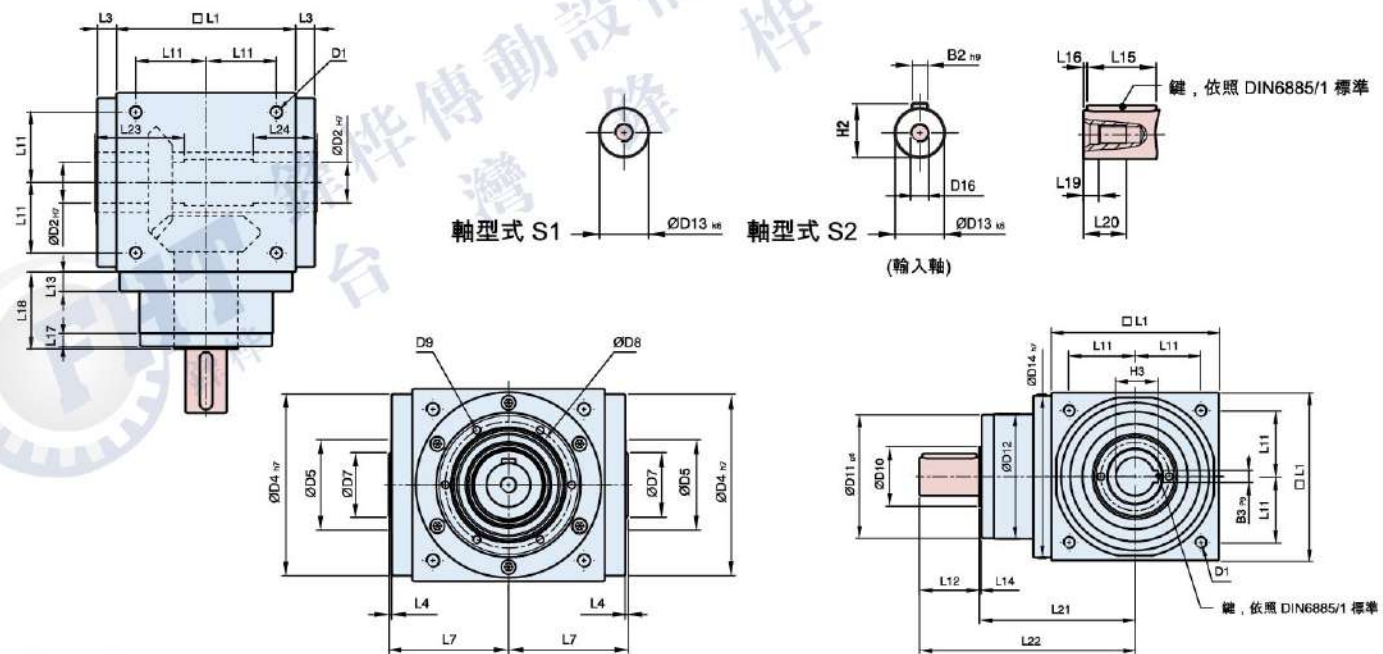

規格表 Specifications:

尺寸 Sizes	AT065 H	AT075 H	AT090 H	AT110 H	AT140 H	AT170 H	AT210 H	AT240 H	AT280 H
D1	M4	M6	M6	M8	M10	M12	M16	M16	M16
D2 _{H7}	13	14	18	22	32	40	50	55	60
D4 _{H7}	63	73	88	108	135	165	205	235	275
D5	31	35	43	53	68	83	104	124	144
D7	21	22	28	33	47	55	75	85	110
D8	53	62	76	95	92	114	142	160	176
D9	4xM4xL7	4xM5xL8	4xM5xL8	6xM6xL10	6xM6xL10	6xM8xL12.5	6xM8xL12.5	6xM8xL12.5	6xM10xL15
D10	15.4	20.4	25.8	35.8	49.8	59.3	79.3	92.3	102.3
D11 _{g6}	62.9	72.9	87	107	103	127	158	178	198
D12	62	72	86	106	104	128	160	180	200
D13 _{k6}	13	16	18	22	32	40	50	55	60
D14 _{H7}	63	73	88	108	135	165	205	235	275
D16	M4	M5	M5	M8	M12	M16	M16	M16	M20
L1	65	75	90	110	140	170	210	240	280
L3	13	14.5	15	15	15	15	20	25	25
L4	2	2	2	2	2	2	2	2	2
L7	47.5	54	62	72	87	102	127	147	167
L11	27	30	36	44	55	67	85	95	110
L12	19.5	30	35	40	50	60	75	85	110
L13	13	15	15	15	15	15	20	25	25
L14	2	2	2	2	2	2	2	2	2
L15	16	25	28	32	45	50	70	80	100
L16	2	2.5	3.5	4	2.5	5	2.5	2.5	5
L17	6	8	8	8	10	10	10	10	10
L18	43	52.5	55	60	60	70	90	105	120
L19	4.5	4.8	4.8	7.2	10	12	12	12	15
L20	10	12.5	12.5	19	28	36	36	36	42
L21	75.5	90	100	115	130	155	195	225	260
L22	95	120	135	155	180	215	270	310	370
L23	40	47	52	53	70	80	95	115	115
L24	30	32	35	35	50	55	65	80	80
B2 _{H9}	5	5	6	6	10	12	14	16	18
B3 _{P9}	5	5	6	6	10	12	14	16	18
H2	15	18	20.5	24.5	35	43	53.5	59	64
H3	15.3	16.3	20.8	24.8	35.3	43.3	53.8	59.3	64.4

Unit:mm

AT-C系列孔輸出帶抱箍型式

Hole Output Hoop Type

尺寸 (單節1-stage, 減速比ratio i=1~5)



外形尺寸圖 Dimensions:

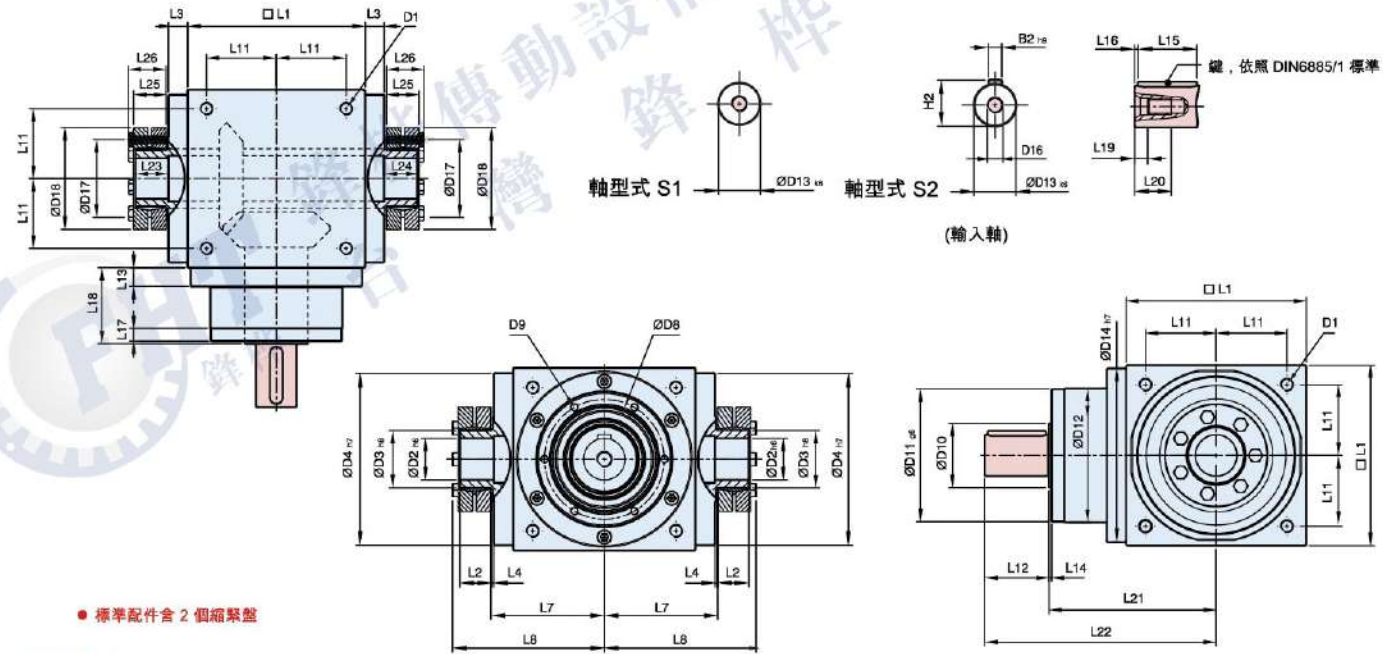

規格表 Specifications:

尺寸 Sizes	AT065 C	AT075 C	AT090 C	AT110 C	AT140 C	AT170 C	AT210 C	AT240 C	AT280 C
D1	M4	M6	M6	M8	M10	M12	M16	M16	M16
D2 _{H6}	13	14	18	22	32	40	50	55	60
D3 _{H8}	16	16	22	25	44	50	62	68	75
D4 _{H7}	63	73	88	108	135	165	205	235	275
D8	53	62	76	95	92	114	142	160	176
D9	4xM4xL7	4xM5xL8	4xM5xL8	6xM6xL10	6xM6xL10	6xM8xL12.5	6xM8xL12.5	6xM8xL12.5	6xM10xL15
D10	15.4	20.4	25.8	35.8	49.8	59.3	79.3	92.3	102.3
D11 _{g6}	62.9	72.9	87	107	103	127	158	178	198
D12	62	72	86	106	104	128	160	180	200
D13 _{k6}	13	16	18	22	32	40	50	55	60
D14 _{H7}	63	73	88	108	135	165	205	235	275
D16	M4	M5	M5	M8	M12	M16	M16	M16	M20
D17	26	26	36	38	61	70	86	86	100
D18	41	41	50	50	80	90	110	115	138
L1	65	75	90	110	140	170	210	240	280
L2	14	14	18	18	24	26	29	29	30.5
L3	13	14.5	15	15	15	15	20	25	25
L4	2	2	2	2	2	2	2	2	2
L7	47.5	54	62	72	87	102	127	147	167
L8	66	72.5	85	95	116.5	133.5	161.5	181.5	205
L11	27	30	36	44	55	67	85	95	110
L12	19.5	30	35	40	50	60	75	85	110
L13	13	15	15	15	15	15	20	25	25
L14	2	2	2	2	2	2	2	2	2
L15	16	25	28	32	45	50	70	80	100
L16	2	2.5	3.5	4	2.5	5	2.5	2.5	5
L17	6	8	8	8	10	10	10	10	10
L18	43	52.5	55	60	60	70	90	105	120
L19	4.5	4.8	4.8	7.2	10	12	12	12	15
L20	10	12.5	12.5	19	28	36	36	36	42
L21	75.5	90	100	115	130	155	195	225	260
L22	95	120	135	155	180	215	270	310	370
L23	15	15	20	20	26	28	31	31	32.5
L24	15	15	20	20	26	28	31	31	32.5
L25	15	15	19.5	19.5	25.5	27.5	30.5	30.5	32.5
L26	18.5	18.5	23	23	29.5	31.5	34.5	34.5	38
B2 _{H9}	5	5	6	6	10	12	14	16	18
H2	15	18	20.5	24.5	35	43	53.5	59	64

Unit:mm

AT-LM (左) / AT-RM(右)系列 雙出軸方向相反型式

Double Output Shaft Opposite Direction Type
尺寸(單節1-stage, 減速比ratio i=1)



外形尺寸圖 Dimensions:

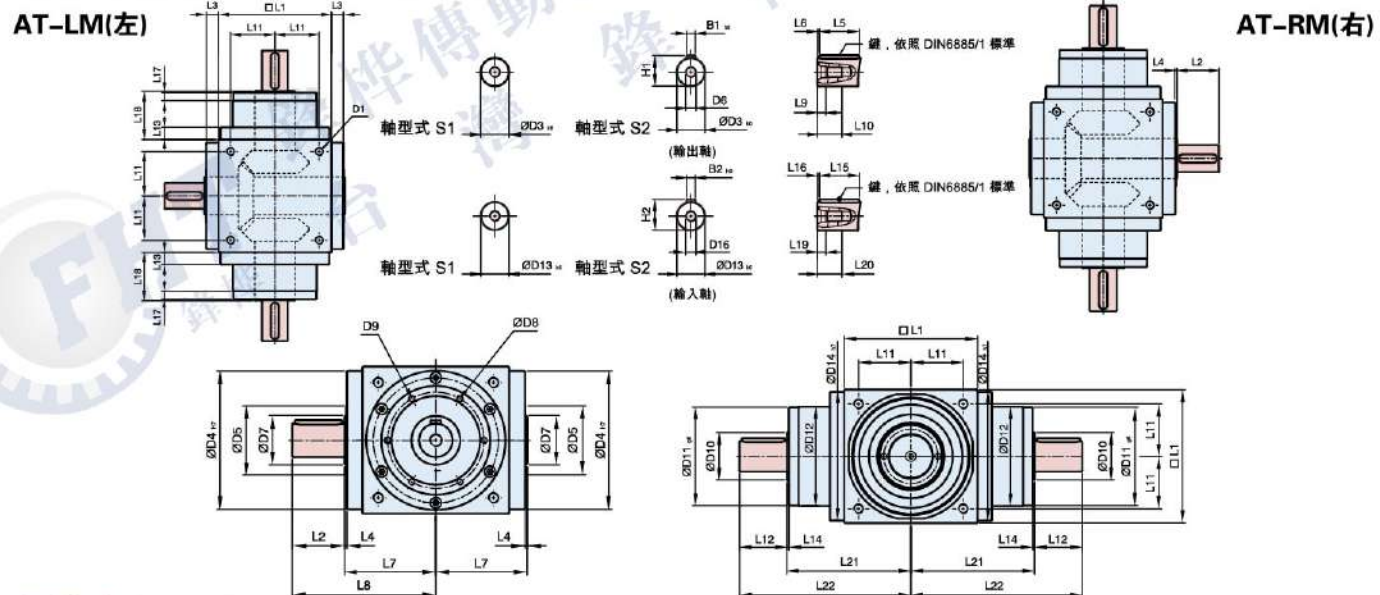

規格表 Specifications:

尺寸 Sizes	AT065LM/RM	AT075LM/RM	AT090LM/RM	AT110LM/RM	AT140LM/RM	AT170LM/RM	AT210LM/RM	AT240LM/RM	AT280LM/RM
D1	M4	M6	M6	M8	M10	M12	M16	M16	M16
D3 k6	13	16	18	22	32	40	50	55	60
D4 h7	63	73	88	108	135	165	205	235	275
D5	31	35	43	53	68	83	104	124	144
D6	M4	M5	M5	M8	M12	M16	M16	M16	M20
D7	21	22	28	33	47	55	75	85	110
D8	53	62	76	95	92	114	142	160	176
D9	4xM4xL7	4xM5xL8	4xM5xL8	6xM6xL10	6xM6xL10	6xM8xL12.5	6xM8xL12.5	6xM8xL12.5	6xM10xL15
D10	15.4	20.4	25.8	35.8	49.8	59.3	79.3	92.3	102.3
D11 g6	62.9	72.9	87	107	103	127	158	178	198
D12	62	72	86	106	104	128	160	180	200
D13 k6	13	16	18	22	32	40	50	55	60
D14 h7	63	73	88	108	135	165	205	235	275
D16	M4	M5	M5	M8	M12	M16	M16	M16	M20
L1	65	75	90	110	140	170	210	240	280
L2	19.5	30	35	40	50	60	75	85	110
L3	13	14.5	15	15	15	15	20	25	25
L4	2	2	2	2	2	2	2	2	2
L5	16	25	28	32	45	50	70	80	100
L6	2	2.5	3.5	4	2.5	5	2.5	2.5	5
L7	47.5	54	62	72	87	102	127	147	167
L8	67	84	97	112	137	162	202	232	277
L9	4.5	4.8	4.8	7.2	10	12	12	12	15
L10	10	12.5	12.5	19	28	36	36	36	42
L11	27	30	36	44	55	67	85	95	110
L12	19.5	30	35	40	50	60	75	85	110
L13	13	15	15	15	15	15	20	25	25
L14	2	2	2	2	2	2	2	2	2
L15	16	25	28	32	45	50	70	80	100
L16	2	2.5	3.5	4	2.5	5	2.5	2.5	5
L17	6	8	8	8	10	10	10	10	10
L18	43	52.5	55	60	60	70	90	105	120
L19	4.5	4.8	4.8	7.2	10	12	12	12	15
L20	10	12.5	12.5	19	28	36	36	36	42
L21	75.5	90	100	115	130	155	195	225	260
L22	95	120	135	155	180	215	270	310	370
B1 h9	5	5	6	6	10	12	14	16	18
B2 h9	5	5	6	6	10	12	14	16	18
H1	15	18	20.5	24.5	35	43	53.5	59	64
H2	15	18	20.5	24.5	35	43	53.5	59	64

AT-4M系列

Series

尺寸(單節1-stage, 減速比ratio i=1)



外形尺寸圖 Dimensions:

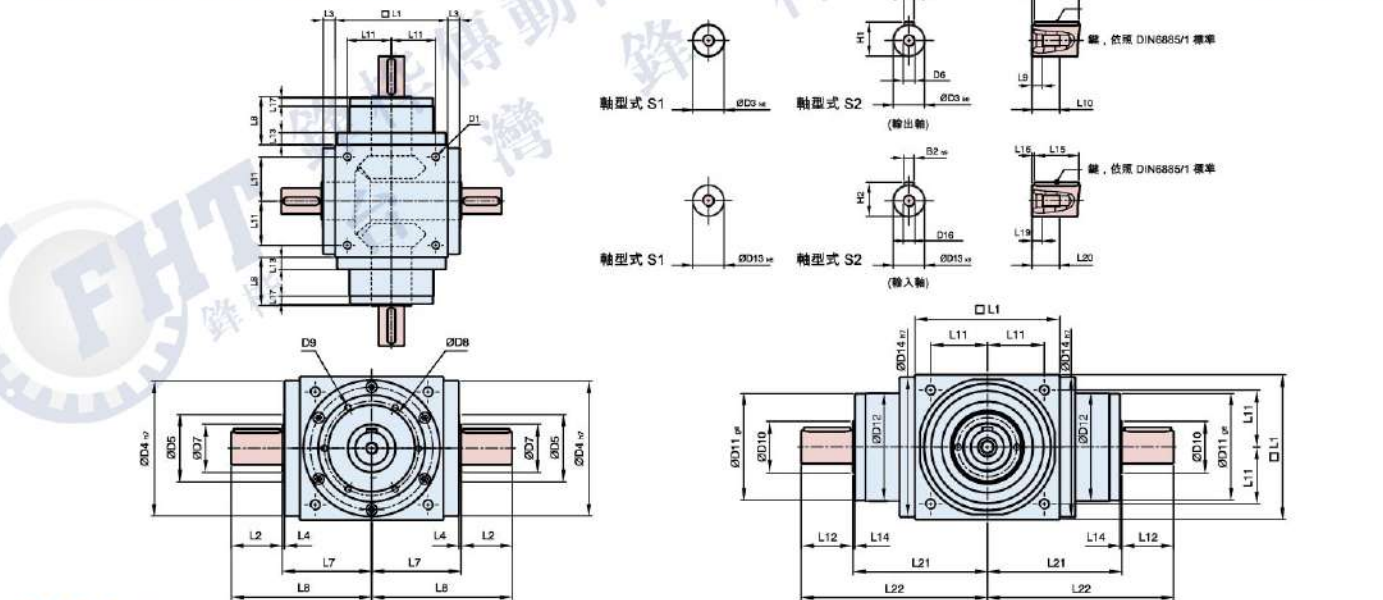

規格表 Specifications:

尺寸 Sizes	AT065 4M	AT075 4M	AT090 4M	AT110 4M	AT140 4M	AT170 4M	AT210 4M	AT240 4M	AT280 4M
D1	M4	M6	M6	M8	M10	M12	M16	M16	M16
D3 k6	13	16	18	22	32	40	50	55	60
D4 h7	63	73	88	108	135	165	205	235	275
D5	31	35	43	53	68	83	104	124	144
D6	M4	M5	M5	M8	M12	M16	M16	M16	M20
D7	21	22	28	33	47	55	75	85	110
D8	53	62	76	95	92	114	142	160	176
D9	4xM4xL7	4xM5xL8	4xM5xL8	6xM6xL10	6xM6xL10	6xM8xL12.5	6xM8xL12.5	6xM8xL12.5	6xM10xL15
D10	15.4	20.4	25.8	35.8	49.8	59.3	79.3	92.3	102.3
D11 g6	62.9	72.9	87	107	103	127	158	178	198
D12	62	72	86	106	104	128	160	180	200
D13 k6	13	16	18	22	32	40	50	55	60
D14 h7	63	73	88	108	135	165	205	235	275
D16	M4	M5	M5	M8	M12	M16	M16	M16	M20
L1	65	75	90	110	140	170	210	240	280
L2	19.5	30	35	40	50	60	75	85	110
L3	13	14.5	15	15	15	15	20	25	25
L4	2	2	2	2	2	2	2	2	2
L5	16	25	28	32	45	50	70	80	100
L6	2	2.5	3.5	4	2.5	5	2.5	2.5	5
L7	47.5	54	62	72	87	102	127	147	167
L8	67	84	97	112	137	162	202	232	277
L9	4.5	4.8	4.8	7.2	10	12	12	12	15
L10	10	12.5	12.5	19	28	36	36	36	42
L11	27	30	36	44	55	67	85	95	110
L12	19.5	30	35	40	50	60	75	85	110
L13	13	15	15	15	15	15	20	25	25
L14	2	2	2	2	2	2	2	2	2
L15	16	25	28	32	45	50	70	80	100
L16	2	2.5	3.5	4	2.5	5	2.5	2.5	5
L17	6	8	8	8	10	10	10	10	10
L18	43	52.5	55	60	60	70	90	105	120
L19	4.5	4.8	4.8	7.2	10	12	12	12	15
L20	10	12.5	12.5	19	28	36	36	36	42
L21	75.5	90	100	115	130	155	195	225	260
L22	95	120	135	155	180	215	270	310	370
B1 h9	5	5	6	6	10	12	14	16	18
B2 h9	5	5	6	6	10	12	14	16	18
H1	15	18	20.5	24.5	35	43	53.5	59	64
H2	15	18	20.5	24.5	35	43	53.5	59	64

AT-FL系列雙出軸型式

Double Output Shaft Type

尺寸 (單節 1-stage, 減速比ratio i=1~5)



外形尺寸圖 Dimensions:

Unit:mm

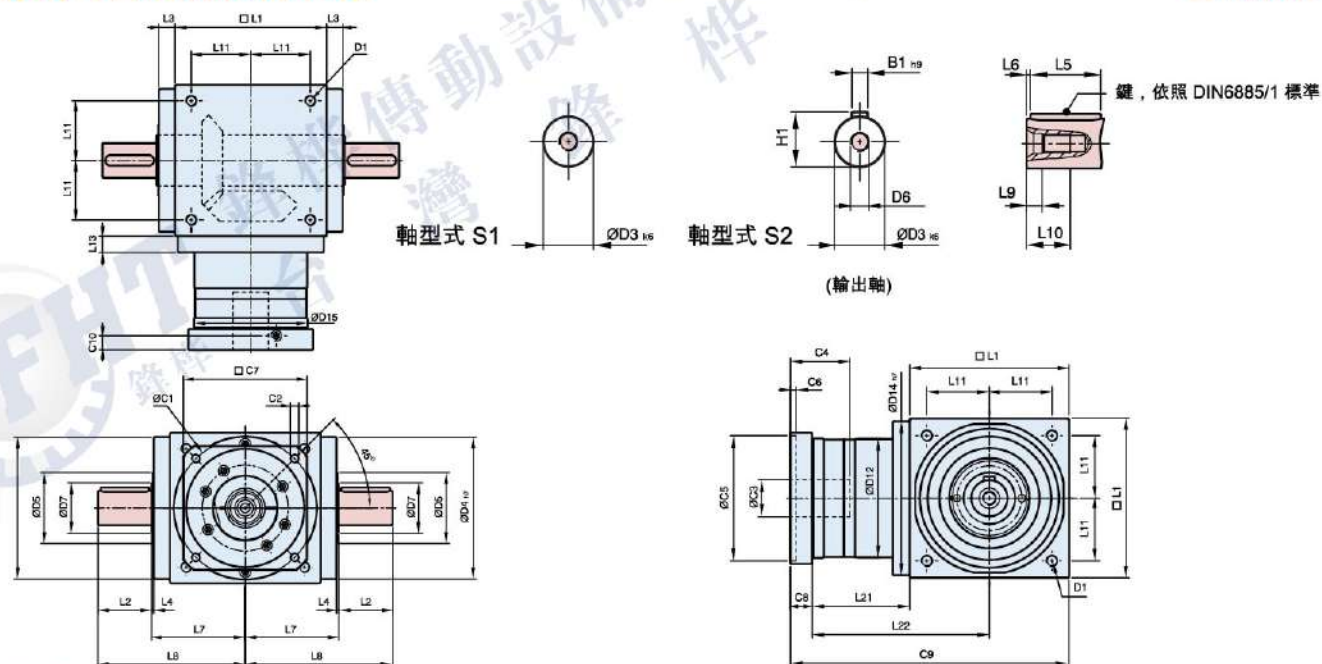

規格表 Specifications:

Unit:mm

尺寸 Sizes	AT065 FL	AT075 FL	AT090 FL	AT110 FL	AT140 FL	AT170 FL	AT210 FL	AT240 FL	AT280 FL
D1	M4	M6	M6	M8	M10	M12	M16	M16	M16
D3 k6	13	16	18	22	32	40	50	55	60
D4 h7	63	73	88	108	135	165	205	235	275
D5	31	35	43	53	68	83	104	124	144
D6	M4	M5	M5	M8	M12	M16	M16	M16	M20
D7	21	22	28	33	47	55	75	85	110
D12	62	72	86	106	104	128	160	180	200
D14 h7	63	73	88	108	135	165	205	235	275
D15	62.9	72.9	87	107	105	127	158	178	198
L1	65	75	90	110	140	170	210	240	280
L2	19.5	30	35	40	50	60	75	85	110
L3	13	14.5	15	15	15	15	20	25	25
L4	2	2	2	2	2	2	2	2	2
L5	16	25	28	32	45	50	70	80	100
L6	2	2.5	3.5	4	2.5	5	2.5	2.5	5
L7	47.5	54	62	72	87	102	127	147	167
L8	67	84	97	112	137	162	202	232	277
L9	4.5	4.8	4.8	7.2	10	12	12	12	15
L10	10	12.5	12.5	19	28	36	36	36	42
L11	27	30	36	44	55	67	85	95	110
L13	13	15	15	15	15	15	20	25	25
L21	49	60.5	63	69.5	85.5	95	130	144.5	135
L22	81.5	98	108	124.5	155.5	180	235	264.5	275
C1 ³	46	70	100	100	130	165	215	215	235
C2 ³	M4	M5	M6	M6	M8	M10	M12	M12	M12
C3 ³	★ ≤11 / ≤12	★ ≤14 / ≤15.875 / ≤16	≤19	≤24	≤32	≤38	≤42	≤48	≤55
C4 ³	30	34	40	40	50	60	85	85	116
C5 ³	30	50	80	80	110	130	180	180	200
C6 ³	3.5	8	4	4	5	6	6	6	6
C7 ³	42	60	90	90	115	142	190	190	220
C8 ³	19.5	19	17	17	19.5	22.5	29	29	63
C9 ³	133.5	154.5	170	196.5	245	287.5	369	413.5	478
C10 ³	13.25	13.5	10.75	10.75	13	15	20.75	20.75	53.5
B1 h9	5	5	6	6	10	12	14	16	18
H1	15	18	20.5	24.5	35	43	53.5	59	64

3. C1~C10 是公制標準馬達連接板之尺寸, 請上網點選"減速機選用"找出正確之尺寸。

★AT065 FLM1 提供 C3 ≤12 option ★AT075 FLM1 提供 C3 ≤16 option ★AT075 FLM2 提供 C3 ≤15.875 option

AT-FL系列雙出軸型式

Double Output Shaft Type

尺寸 (雙節 2-stage, 減速比ratio i=7~50)



外形尺寸圖 Dimensions:

Unit:mm

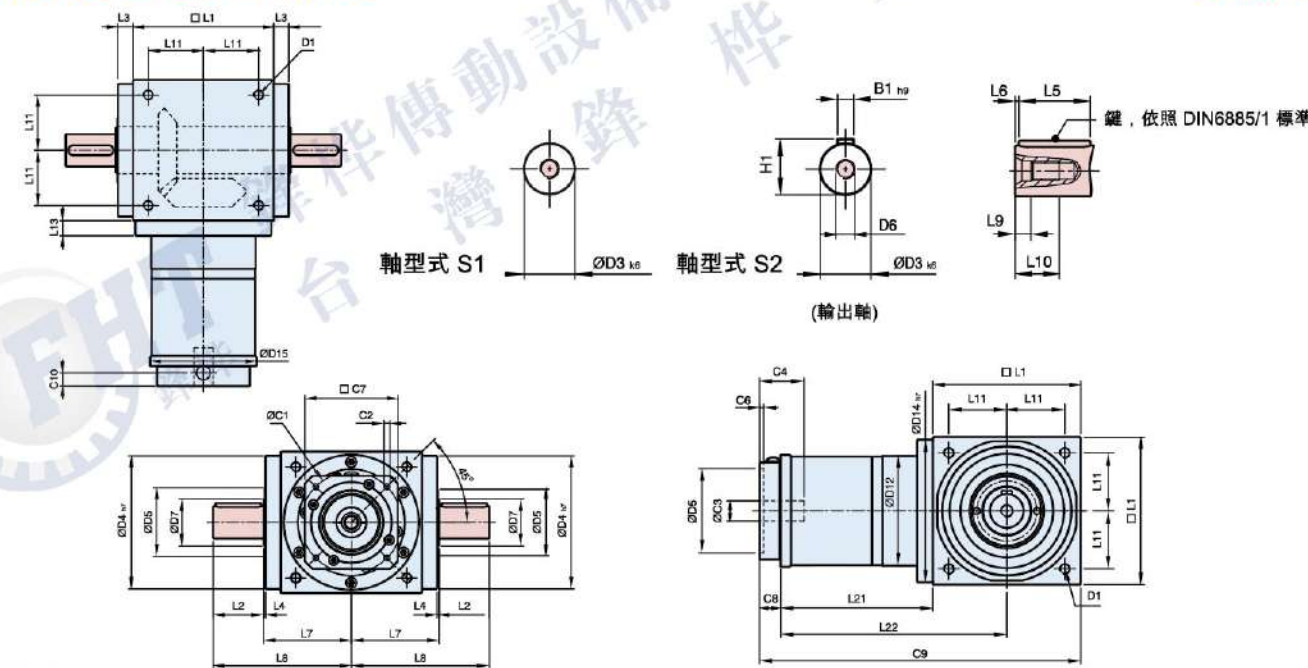

規格表 Specifications:

Unit:mm

尺寸 Sizes	AT065 FL	AT075 FL	AT090 FL	AT110 FL	AT140 FL	AT170 FL	AT210 FL	AT240 FL	AT280 FL
D1	M4	M6	M6	M8	M10	M12	M16	M16	M16
D3 k6	13	16	18	22	32	40	50	55	60
D4 h7	63	73	88	108	135	165	205	235	275
D5	31	35	43	53	68	83	104	124	144
D6	M4	M5	M5	M8	M12	M16	M16	M16	M20
D7	21	22	28	33	47	55	75	85	110
D12	62	72	86	106	104	128	160	180	200
D14 h7	63	73	88	108	135	165	205	235	275
D15	62.9	72.9	87	107	106	127	158	178	198
L1	65	75	90	110	140	170	210	240	280
L2	19.5	30	35	40	50	60	75	85	110
L3	13	14.5	15	15	15	15	20	25	25
L4	2	2	2	2	2	2	2	2	2
L5	16	25	28	32	45	50	70	80	100
L6	2	2.5	3.5	4	2.5	5	2.5	2.5	5
L7	47.5	54	62	72	87	102	127	147	167
L8	67	84	97	112	137	162	202	232	277
L9	4.5	4.8	4.8	7.2	10	12	12	12	15
L10	10	12.5	12.5	19	28	36	36	36	42
L11	27	30	36	44	55	67	85	95	110
L13	13	15	15	15	15	15	20	25	25
L21	75	84.5	99	122	144.5	157.5	206.5	239	248
L22	107.5	122	144	177	214.5	242.5	311.5	359	388
C1 ⁴	46	46	70	100	100	130	165	165	165
C2 ⁴	M4	M4	M5	M6	M6	M6	M8	M10	M10
C3 ⁴	≤12	≤12	≤16	≤24	≤24	≤24	≤32	≤38	≤38
C4 ⁴	30	30	34	40	40	40	50	60	60
C5 ⁴	30	30	50	80	80	80	110	130	130
C6 ⁴	3.5	3.5	8	4	4	4	5	6	6
C7 ⁴	42	42	60	92	92	92	115	142	142
C8 ⁴	21.5	21.5	21.5	20	20	20	24	31	31
C9 ⁴	161.5	181	210.5	252	304.5	347.5	440.5	510	559
C10 ⁴	14.5	14.5	15.5	13	13	13	16	21	21
B1 h9	5	5	6	6	10	12	14	16	18
H1	15	18	20.5	24.5	35	43	53.5	59	64

4. C1~C10 是公制標準馬達連接板之尺寸, 請上網點選"減速機選用"找出正確之尺寸。

AT-FL系列雙出軸型式

Double Output Shaft Type

尺寸 (三節 3-stage, 減速比ratio i=75~500)



外形尺寸圖 Dimensions:

Unit:mm

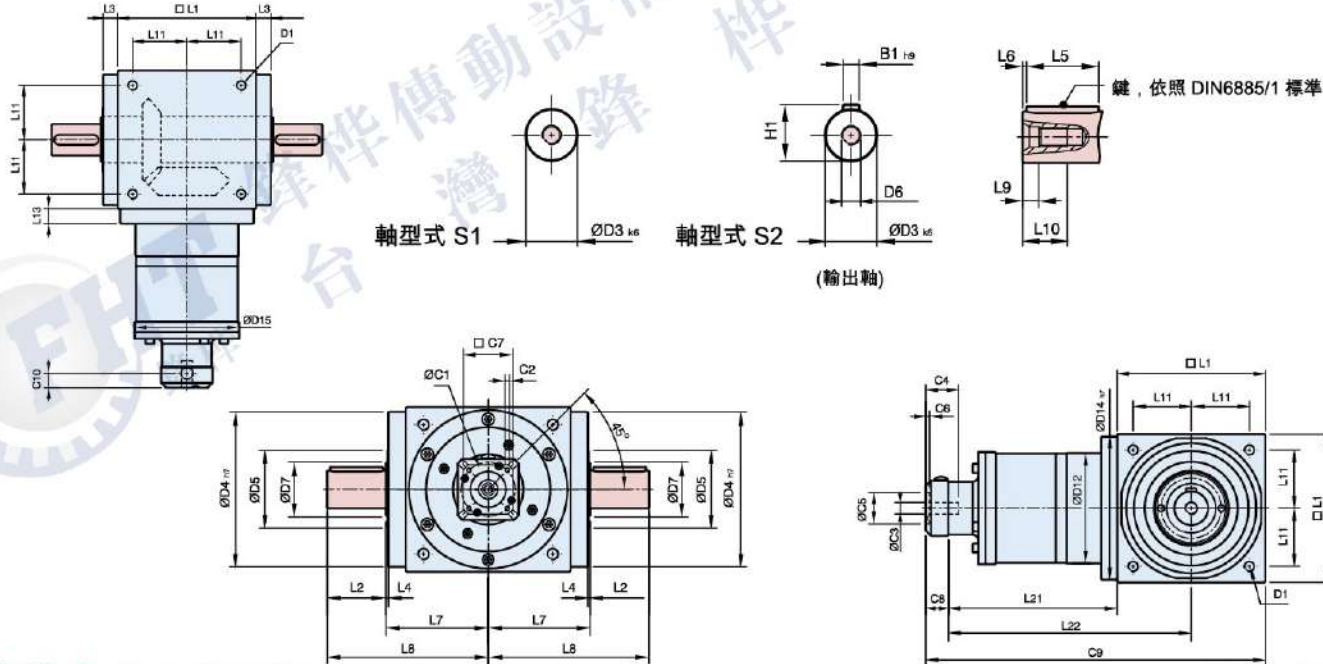

規格表 Specifications:

Unit:mm

尺寸	AT110 FL	AT140 FL	AT170 FL	AT210 FL	AT240 FL	AT280 FL
D1	M8	M10	M12	M16	M16	M16
D3 _{k6}	22	32	40	50	55	60
D4 _{h7}	108	135	165	205	235	275
D5	53	68	83	104	124	144
D6	M8	M12	M16	M16	M16	M20
D7	33	47	55	75	85	110
D12	106	104	128	160	180	200
D14 _{h7}	108	135	165	205	235	275
D15	107	106	127	158	178	198
L1	110	140	170	210	240	280
L2	40	50	60	75	85	110
L3	15	15	15	20	25	25
L4	2	2	2	2	2	2
L5	32	45	50	70	80	100
L6	4	2.5	5	2.5	2.5	5
L7	72	87	102	127	147	167
L8	112	137	162	202	232	277
L9	7.2	10	12	12	12	15
L10	19	28	36	36	36	42
L11	44	55	67	85	95	110
L13	15	15	15	20	25	25
L21	136.5	159.5	183.5	226	269	278
L22	191.5	229.5	268.5	331	389	418
C1 ⁵	46	46	70	70	100	100
C2 ⁵	M4	M4	M5	M5	M6	M6
C3 ⁵	≤12	≤12	≤16	≤16	≤24	≤24
C4 ⁵	30	30	34	34	40	40
C5 ⁵	30	30	50	50	80	80
C6 ⁵	3.5	3.5	8	8	4	4
C7 ⁵	42	42	60	60	92	92
C8 ⁵	21.5	21.5	21.5	21.5	20	20
C9 ⁵	268	321	375	457.5	529	578
C10 ⁵	14.5	14.5	15.5	15.5	13	13
B1 _{h9}	6	10	12	14	16	18
H1	24.5	35	43	53.5	59	64

5. C1~C10 是公制標準馬達連接板之尺寸, 請上網點選"減速機選用"找出正確之尺寸。

AT-FL1 (左) / AT-FR1(右)系列

單出軸型式 Single Output Shaft Type

尺寸 (單節 1-stage, 減速比ratio i=1~5)



外形尺寸圖 Dimensions:

Unit:mm

AT-FL1(左)

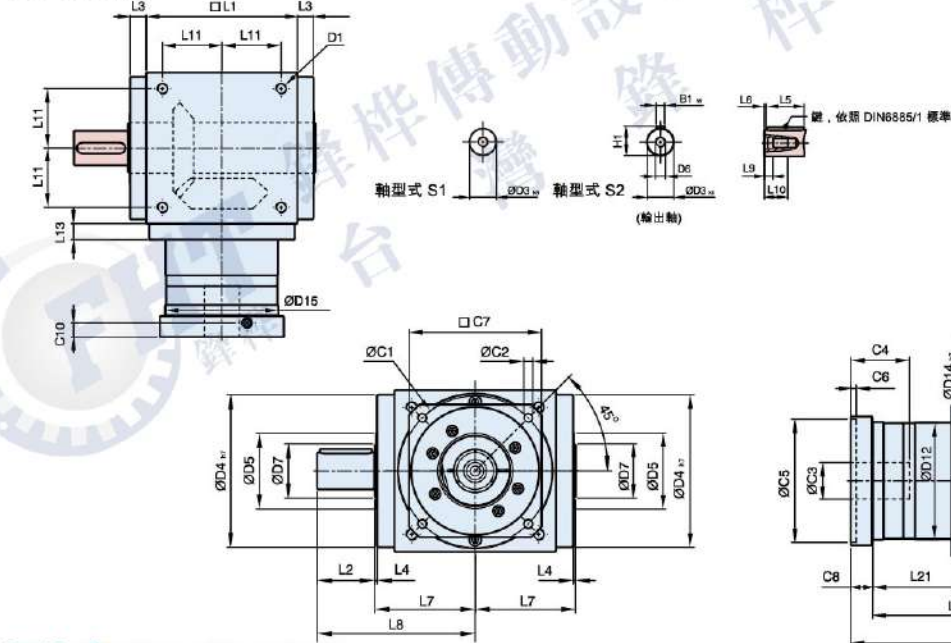

規格表 Specifications:

Unit:mm

尺寸	AT065 FL1/FR1	AT075 FL1/FR1	AT090 FL1/FR1	AT110 FL1/FR1	AT140 FL1/FR1	AT170 FL1/FR1	AT210 FL1/FR1	AT240 FL1/FR1	AT280 FL1/FR1
D1	M4	M6	M6	M8	M10	M12	M16	M16	M16
D3 _{k6}	13	16	18	22	32	40	50	55	60
D4 _{h7}	63	73	88	108	135	165	205	235	275
D5	31	35	43	53	68	83	104	124	144
D6	M4	M5	M5	M8	M12	M16	M16	M16	M20
D7	21	22	28	33	47	55	75	85	110
D12	62	72	86	106	104	128	160	180	200
D14 _{h7}	63	73	88	108	135	165	205	235	275
D15	62.9	72.9	87	107	105	127	158	178	198
L1	65	75	90	110	140	170	210	240	280
L2	19.5	30	35	40	50	60	75	85	110
L3	13	14.5	15	15	15	15	20	25	25
L4	2	2	2	2	2	2	2	2	2
L5	16	25	28	32	45	50	70	80	100
L6	2	2.5	3.5	4	2.5	5	2.5	2.5	5
L7	47.5	54	62	72	87	102	127	147	167
L8	67	84	97	112	137	162	202	232	277
L9	4.5	4.8	4.8	7.2	10	12	12	12	15
L10	10	12.5	12.5	19	28	36	36	36	42
L11	27	30	36	44	55	67	85	95	110
L13	13	15	15	15	15	15	20	25	25
L21	49	60.5	63	69.5	85.5	95	130	144.5	135
L22	81.5	98	108	124.5	155.5	180	235	264.5	275
C1 ⁵	46	70	100	100	130	165	215	215	235
C2 ⁵	M4	M5	M6	M6	M8	M10	M12	M12	M12
C3 ⁵	★≤11 / ≤12	★≤14 / ≤15.875 / ≤16	≤19	≤24	≤32	≤38	≤42	≤48	≤55
C4 ⁵	30	34	40	40	50	60	85	85	116
C5 ⁵	30	50	80	80	110	130	180	180	200
C6 ⁵	3.5	8	4	4	5	6	6	6	6
C7 ⁵	42	60	90	90	115	142	190	190	220
C8 ⁵	19.5	19	17	17	19.5	22.5	29	29	63
C9 ⁵	133.5	154.5	170	196.5	245	287.5	369	413.5	478
C10 ⁵	13.25	13.5	10.75	10.75	13	15	20.75	20.75	53.5
B1 _{h9}	5	5	6	6	10	12	14	16	18
H1	15	18	20.5	24.5	35	43	53.5	59	64

6. C1~C10 是公制標準馬達連接板之尺寸, 請上網點選"減速機選用"找出正確之尺寸。

★ AT065 FL1/FR1M1 提供 C3 ≤12 option. ★ AT075 FL1/FR1M1提供 C3 ≤16 option. ★ AT075 FL1/FR1M2提供 C3 ≤15.875 option.

AT-FL1 (左) / AT-FR1(右)系列

單出軸型式 Single Output Shaft Type

尺寸 (雙節 2-stage, 減速比ratio i=7~50)



外形尺寸圖 Dimensions:

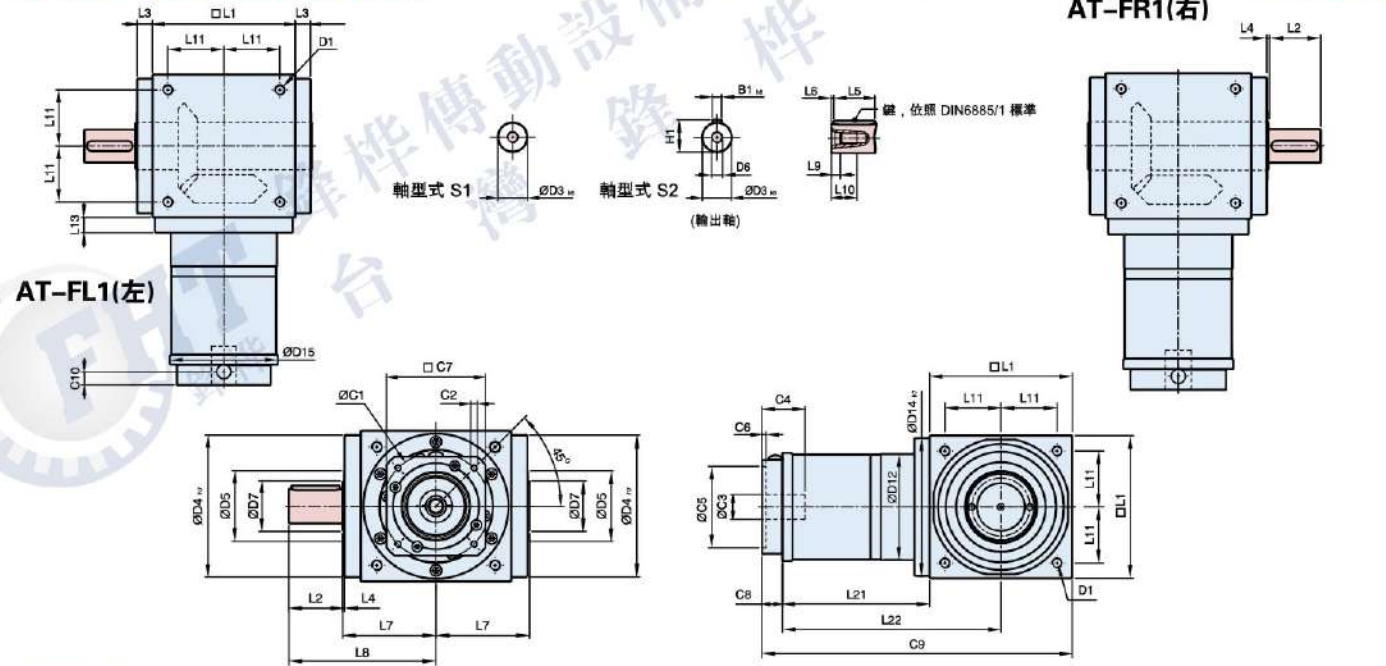

規格表 Specifications:

尺寸 Sizes	AT065 FL1/FR1	AT075 FL1/FR1	AT090 FL1/FR1	AT110 FL1/FR1	AT140 FL1/FR1	AT170 FL1/FR1	AT210 FL1/FR1	AT240 FL1/FR1	AT280 FL1/FR1
D1	M4	M6	M6	M8	M10	M12	M16	M16	M16
D3 _{k6}	13	16	18	22	32	40	50	55	60
D4 _{h7}	63	73	88	108	135	165	205	235	275
D5	31	35	43	53	68	83	104	124	144
D6	M4	M5	M5	M8	M12	M16	M16	M16	M20
D7	21	22	28	33	47	55	75	85	110
D12	62	72	86	106	104	128	160	180	200
D14 _{h7}	63	73	88	108	135	165	205	235	275
D15	62.9	72.9	87	107	106	127	158	178	198
L1	65	75	90	110	140	170	210	240	280
L2	19.5	30	35	40	50	60	75	85	110
L3	13	14.5	15	15	15	15	20	25	25
L4	2	2	2	2	2	2	2	2	2
L5	16	25	28	32	45	50	70	80	100
L6	2	2.5	3.5	4	2.5	5	2.5	5	5
L7	47.5	54	62	72	87	102	127	147	167
L8	67	84	97	112	137	162	202	232	277
L9	4.5	4.8	4.8	7.2	10	12	12	12	15
L10	10	12.5	12.5	19	28	36	36	36	42
L11	27	30	36	44	55	67	85	95	110
L13	13	15	15	15	15	15	20	25	25
L21	75	84.5	99	122	144.5	157.5	206.5	239	248
L22	107.5	122	144	177	214.5	242.5	311.5	359	388
C1 ⁷	46	46	70	100	100	100	130	165	165
C2 ⁷	M4	M4	M5	M6	M6	M6	M8	M10	M10
C3 ⁷	≤12	≤12	≤16	≤24	≤24	≤24	≤32	≤38	≤38
C4 ⁷	30	30	34	40	40	40	50	60	60
C5 ⁷	30	30	50	80	80	80	110	130	130
C6 ⁷	3.5	3.5	8	4	4	4	5	6	6
C7 ⁷	42	42	60	92	92	92	115	142	142
C8 ⁷	21.5	21.5	21.5	20	20	20	24	31	31
C9 ⁷	161.5	181	210.5	252	304.5	347.5	440.5	510	559
C10 ⁷	14.55	14.5	15.5	13	13	13	16	21	21
B1 _{h9}	5	5	6	6	10	12	14	16	18
H1	15	18	20.5	24.5	35	43	53.5	59	64

7. C1~C10 是公制標準馬達連接板之尺寸, 請上網點選"減速機選用"找出正確之尺寸。

AT-FL1 (左) / AT-FR1(右)系列

單出軸型式 Single Output Shaft Type

尺寸 (三節 3-stage, 減速比ratio i=75~500)



外形尺寸圖 Dimensions:

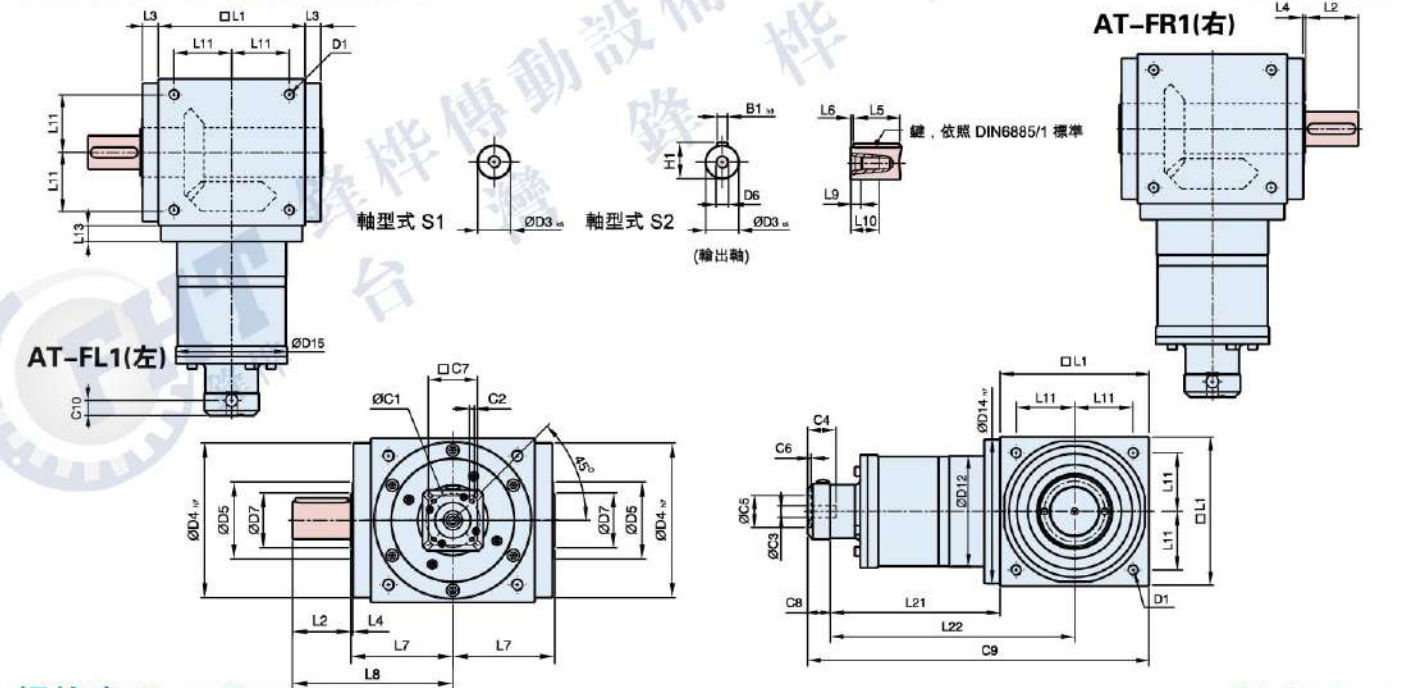

規格表 Specifications:

尺寸 Sizes	AT110 FL1/FR1	AT140 FL1/FR1	AT170 FL1/FR1	AT210 FL1/FR1	AT240 FL1/FR1	AT280 FL1/FR1
D1	M8	M10	M12	M16	M16	M16
D3 _{k6}	22	32	40	50	55	60
D4 _{h7}	108	135	165	205	235	275
D5	53	68	83	104	124	144
D6	M8	M12	M16	M16	M16	M20
D7	33	47	55	75	85	110
D12	106	104	128	160	180	200
D14 _{h7}	108	135	165	205	235	275
D15	107	106	127	158	178	198
L1	110	140	170	210	240	280
L2	40	50	60	75	85	110
L3	15	15	15	20	25	25
L4	2	2	2	2	2	2
L5	32	45	50	70	80	100
L6	4	2.5	5	2.5	5	5
L7	72	87	102	127	147	167
L8	112	137	162	202	232	277
L9	7.2	10	12	12	12	15
L10	19	28	36	36	36	42
L11	44	55	67	85	95	110
L13	15	15	15	20	25	25
L21	136.5	159.5	183.5	226	269	278
L22	191.5	229.5	268.5	331	389	418
C1 ⁹	46	46	70	100	100	100
C2 ⁹	M4	M4	M5	M5	M6	M6
C3 ⁹	≤12	≤12	≤16	≤16	≤24	≤24
C4 ⁹	30	30	34	34	40	40
C5 ⁹	30	30	50	50	80	80
C6 ⁹	3.5	3.5	8	4	4	4
C7 ⁹	42	42	60	60	92	92
C8 ⁹	21.5	21.5	21.5	21.5	20	20
C9 ⁹	268	321	375	457.5	529	578
C10 ⁹	14.5	14.5	15.5	15.5	13	13
B1 _{h9}	6	10	12	14	16	18
H1	24.5	35	43	53.5	59	64

8. C1~C10 是公制標準馬達連接板之尺寸, 請上網點選"減速機選用"找出正確之尺寸。

AF-FH系列孔輸出型式

Hole Output Type

尺寸 (單節 1-stage, 減速比ratio i=1~5)



外形尺寸圖 Dimensions:

Unit:mm

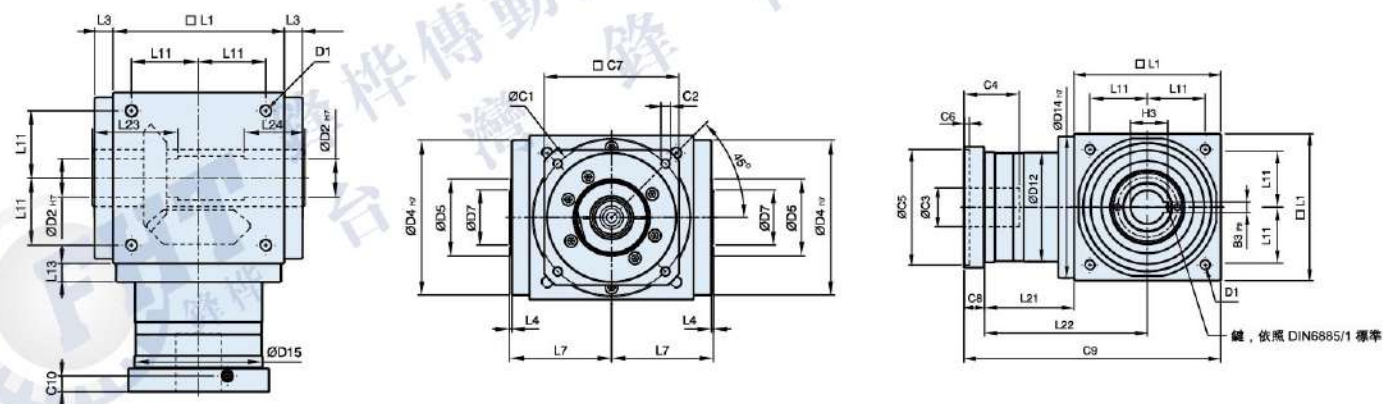

規格表 Specifications:

Unit:mm

尺寸 Sizes	AT065FH	AT075FH	AT090FH	AT110FH	AT140FH	AT170FH	AT210FH	AT240FH	AT280FH
D1	M4	M6	M6	M8	M10	M12	M16	M16	M16
D2 _{H7}	13	14	18	22	32	40	50	55	60
D4 _{H7}	63	73	88	108	135	165	205	235	275
D5	31	35	43	53	68	83	104	124	144
D7	21	22	28	33	47	55	75	85	110
D12	62	72	86	106	104	128	160	180	200
D14 _{H7}	63	73	88	108	135	165	205	235	275
D15	62.9	72.9	87	107	105	127	158	178	198
L1	65	75	90	110	140	170	210	240	280
L3	13	14.5	15	15	15	15	20	25	25
L4	2	2	2	2	2	2	2	2	2
L7	47.5	54	62	72	87	102	127	147	167
L11	27	30	36	44	55	67	85	95	110
L13	13	15	15	15	15	15	20	25	25
L21	49	60.5	63	69.5	85.5	95	130	144.5	135
L22	81.5	98	108	124.5	155.5	180	235	264.5	275
L23	40	47	52	53	70	80	95	115	115
L24	30	32	35	35	50	55	65	80	80
C1 ⁹	46	70	100	100	130	165	215	215	235
C2 ⁹	M4	M5	M6	M6	M8	M10	M12	M12	M12
C3 ⁹	* ≤11 / ≤12	* ≤14 / ≤15.875 / ≤16	≤19	≤24	≤32	≤38	≤42	≤48	≤55
C4 ⁹	30	34	40	40	50	60	85	85	116
C5 ⁹	30	50	80	80	110	130	180	180	200
C6 ⁹	3.5	8	4	4	5	6	6	6	6
C7 ⁹	42	60	90	90	115	142	190	190	220
C8 ⁹	19.5	19	17	17	19.5	22.5	29	29	63
C9 ⁹	133.5	154.5	170	196.5	245	287.5	369	413.5	478
C10 ⁹	13.25	13.5	10.75	10.75	13	15	20.75	20.75	53.5
B3 _{P9}	5	5	6	6	10	12	14	16	18
H3	15.3	16.3	20.8	24.8	35.3	43.3	53.8	59.3	64.4

9. C1-C10 是公制標準馬達連接板之尺寸, 請上網點選"減速機選用"找出正確之尺寸。

* AT065 FHM1 提供 C3 ≤12 option. * AT075 FHM1 提供 C3 ≤16 option. * AT075 FHM2 提供 C3 ≤15.875 option.

AF-FH系列孔輸出型式

Hole Output Type

尺寸 (雙節 2-stage, 減速比ratio i=7~50)



外形尺寸圖 Dimensions:

Unit:mm

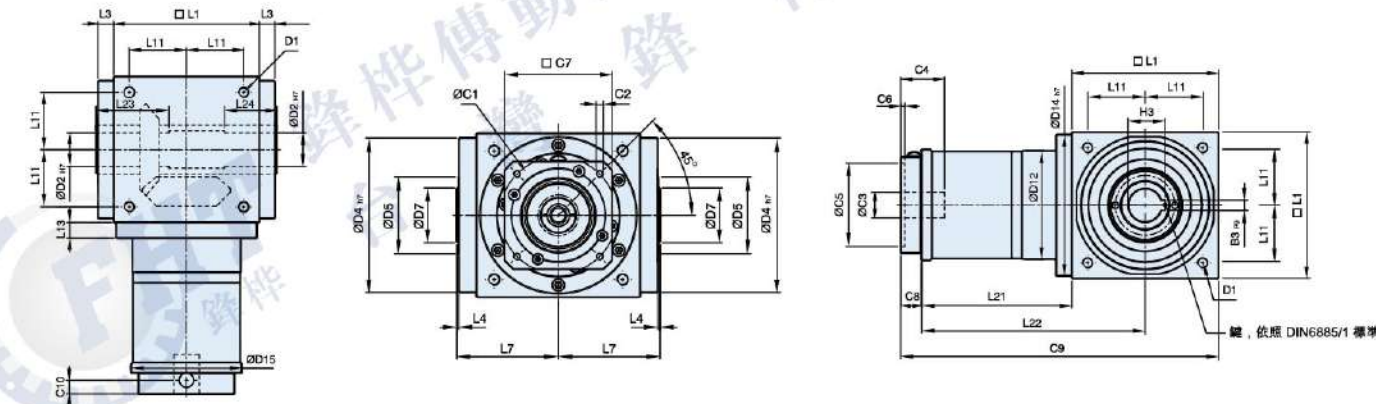

規格表 Specifications:

Unit:mm

尺寸 Sizes	AT065FH	AT075FH	AT090FH	AT110FH	AT140FH	AT170FH	AT210FH	AT240FH	AT280FH
D1	M4	M6	M6	M8	M10	M12	M16	M16	M16
D2 _{H7}	13	14	18	22	32	40	50	55	60
D4 _{H7}	63	73	88	108	135	165	205	235	275
D5	31	35	43	53	68	83	104	124	144
D7	21	22	28	33	47	55	75	85	110
D12	62	72	86	106	104	128	160	180	200
D14 _{H7}	63	73	88	108	135	165	205	235	275
D15	62.9	72.9	87	107	106	127	158	178	198
L1	65	75	90	110	140	170	210	240	280
L3	13	14.5	15	15	15	15	20	25	25
L4	2	2	2	2	2	2	2	2	2
L7	47.5	54	62	72	87	102	127	147	167
L11	27	30	36	44	55	67	85	95	110
L13	13	15	15	15	15	15	20	25	25
L21	75	84.5	99	122	144.5	157.5	206.5	239	248
L22	107.5	122	144	177	214.5	242.5	311.5	359	388
L23	40	47	52	53	70	80	95	115	115
L24	30	32	35	35	50	55	65	80	80
C1 ¹⁰	46	46	70	100	100	130	165	165	165
C2 ¹⁰	M4	M4	M5	M6	M6	M6	M8	M10	M10
C3 ¹⁰	≤12	≤12	≤16	≤24	≤24	≤24	≤32	≤38	≤38
C4 ¹⁰	30	30	34	40	40	40	50	60	60
C5 ¹⁰	30	30	50	80	80	80	110	130	130
C6 ¹⁰	3.5	3.5	8	4	4	4	5	6	6
C7 ¹⁰	42	42	60	92	92	92	115	142	142
C8 ¹⁰	21.5	21.5	21.5	20	20	20	24	31	31
C9 ¹⁰	161.5	181	210.5	252	304.5	347.5	440.5	510	559
C10 ¹⁰	14.5	14.5	15.5	13	13	13	16	21	21
B3 _{P9}	5	5	6	6	10	12	14	16	18
H3	15.3	16.3	20.8	24.8	35.3	43.3	53.8	59.3	64.4

10. C1-C10 是公制標準馬達連接板之尺寸, 請上網點選"減速機選用"找出正確之尺寸。

AT-FH系列孔輸出型式

Hole Output Type

尺寸 (三節 3-stage, 減速比ratio i=75~500)



外形尺寸圖 Dimensions:

Unit:mm

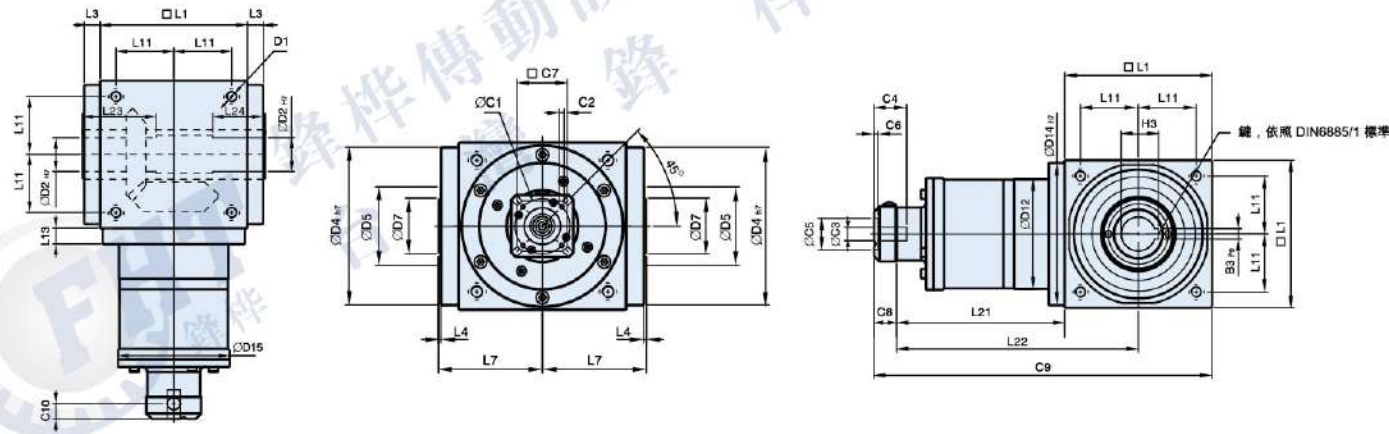

規格表 Specifications:

Unit:mm

尺寸 Sizes	AT110FH	AT140FH	AT170FH	AT210FH	AT240FH	AT280FH
D1	M8	M10	M12	M16	M16	M16
D2 _{H7}	22	32	40	50	55	60
D4 _{H7}	108	135	165	205	235	275
D5	53	68	83	104	124	144
D7	33	47	55	75	85	110
D12	106	104	128	160	180	200
D14 _{H7}	108	135	165	205	235	275
D15	107	106	127	158	178	198
L1	110	140	170	210	240	280
L3	15	15	15	20	25	25
L4	2	2	2	2	2	2
L7	72	87	102	127	147	167
L11	44	55	67	85	95	110
L13	15	15	15	20	25	25
L21	136.5	159.5	183.5	226	269	278
L22	191.5	229.5	268.5	331	389	418
L23	53	70	80	95	115	115
L24	35	50	55	65	80	80
C1 ¹¹	46	46	70	70	100	100
C2 ¹¹	M4	M4	M5	M5	M6	M6
C3 ¹¹	≤12	≤12	≤16	≤16	≤24	≤24
C4 ¹¹	30	30	34	34	40	40
C5 ¹¹	30	30	50	50	80	80
C6 ¹¹	3.5	3.5	8	8	4	4
C7 ¹¹	42	42	60	60	92	92
C8 ¹¹	21.5	21.5	21.5	21.5	20	20
C9 ¹¹	268	321	375	457.5	529	578
C10 ¹¹	14.5	14.5	15.5	15.5	13	13
B3 _{P9}	6	10	12	14	16	18
H3	24.8	35.3	43.3	53.8	59.3	64.4

11. C1-C10 是公制標準馬達連接板之尺寸, 請上網點選"減速機選用"找出正確之尺寸。

AT-FC系列孔輸出帶抱箍型式

Hole Output Hoop Type

尺寸 (單節 1-stage, 減速比ratio i=1~5)



外形尺寸圖 Dimensions:

Unit:mm

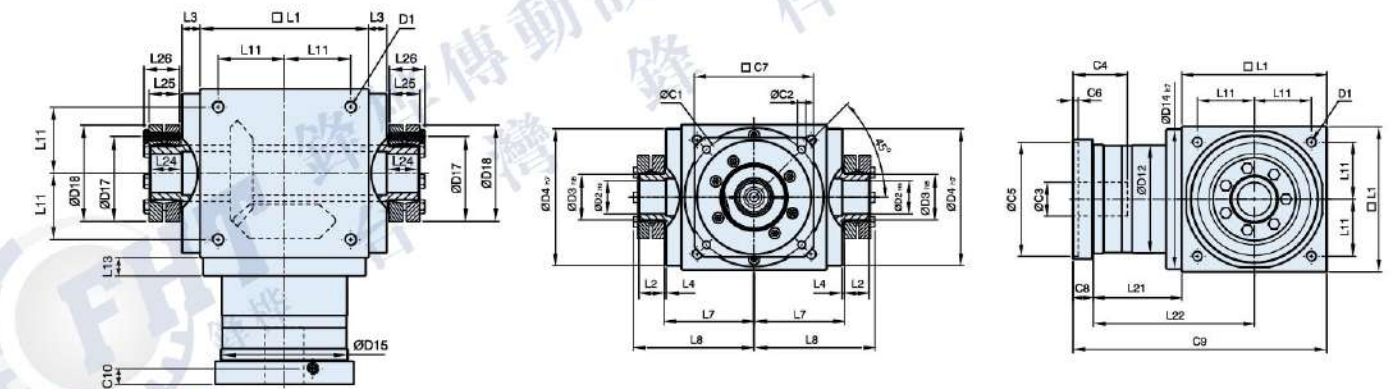

● 標準配件含 2 個鎖緊墊

規格表 Specifications:

Unit:mm

尺寸 Sizes	AT065FC	AT075FC	AT090FC	AT110FC	AT140FC	AT170FC	AT210FC	AT240FC	AT280FC
D1	M4	M6	M6	M8	M10	M12	M16	M16	M16
D2 _{H6}	13	14	18	22	32	40	50	55	60
D3 _{H6}	16	16	22	25	44	50	62	68	75
D4 _{H7}	63	73	88	108	135	165	205	235	275
D12	62	72	86	106	104	128	160	180	200
D14 _{H7}	63	73	88	108	135	165	205	235	275
D15	62.9	72.9	87	107	105	130	158	178	198
D17	26	26	36	38	61	70	86	86	100
D18	41	41	50	50	80	90	110	115	138
L1	65	75	90	110	140	170	210	240	280
L2	14	14	18	18	24	26	29	29	30.5
L3	13	14.5	15	15	15	15	20	25	25
L4	2	2	2	2	2	2	2	2	2
L7	47.5	54	62	72	87	102	127	147	167
L8	66	72.5	85	95	116.5	113.5	161.5	181.5	205
L11	27	30	36	44	55	67	85	95	110
L13	13	15	15	15	15	15	20	25	25
L21	49	60.5	63	69.5	85.5	95	130	144.5	135
L22	81.5	98	108	124.5	155.5	180	235	264.5	275
L23	15	15	20	20	26	28	31	31	32.5
L24	15	15	20	20	26	28	31	31	32.5
L25	15	15	19.5	19.5	25.5	27.5	30.5	30.5	32.5
L26	18.5	18.5	23	23	29.5	31.5	34.5	34.5	38
C1 ¹²	46	70	100	100	130	165	215	215	235
C2 ¹²	M4	M5	M6	M6	M8	M10	M12	M12	M12
C3 ¹²	★ ≤11 / ≤12	★ ≤14 / ≤15.875 / ≤16	≤19	≤24	≤32	≤38	≤42	≤48	≤55
C4 ¹²	30	34	40	40	50	60	85	85	116
C5 ¹²	30	50	80	80	110	130	180	180	200
C6 ¹²	3.5	8	4	4	5	6	6	6	6
C7 ¹²	42	60	90	90	115	142	190	190	220
C8 ¹²	19.5	19	17	17	19.5	22.5	29	29	63
C9 ¹²	133.5	154.5	170	196.5	245	287.5	369	413.5	478
C10 ¹²	13.25	13.5	10.75	10.75	13	15	20.75	20.75	53.5

12. C1-C10 是公制標準馬達連接板之尺寸, 請上網點選"減速機選用"找出正確之尺寸。

★ AT065 FCM1 提供 C3 ≤12 option. ★ AT075 FCM1 提供 C3 ≤16 option. ★ AT075 FCM2 提供 C3 ≤15.875 option.

AT-FC系列孔輸出帶抱箍

Hole Output Hoop Type

尺寸 (雙節 2-stage, 減速比ratio i=7~50)



外形尺寸圖 Dimensions:

Unit:mm

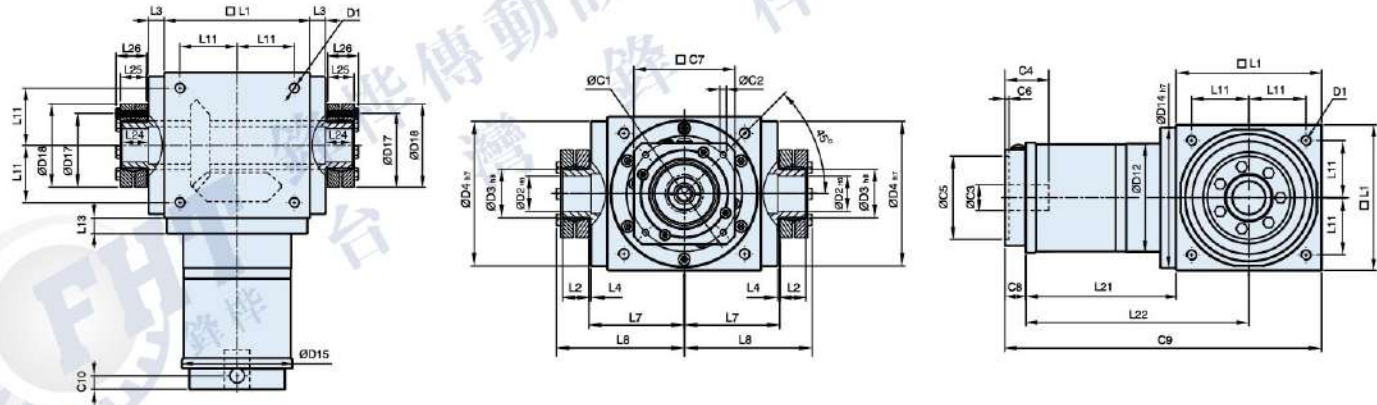

● 標準配件含 2 個縮緊盤

規格表 Specifications:

Unit:mm

尺寸 Sizes	AT065FC	AT075FC	AT090FC	AT110FC	AT140FC	AT170FC	AT210FC	AT240FC	AT280FC
D1	M4	M6	M6	M8	M10	M12	M16	M16	M16
D2 H6	13	14	18	22	32	40	50	55	60
D3 h8	16	16	22	25	44	50	62	68	75
D4 h7	63	73	88	108	135	165	205	235	275
D12	62	72	86	106	104	128	160	180	200
D14 h7	63	73	88	108	135	165	205	235	275
D15	62.9	72.9	87	107	106	127	158	178	198
D17	26	26	36	38	61	70	86	86	100
D18	41	41	50	50	80	90	110	115	138
L1	65	75	90	110	140	170	210	240	280
L2	14	14	18	18	24	26	29	29	30.5
L3	13	14.5	15	15	15	15	20	25	25
L4	2	2	2	2	2	2	2	2	2
L7	47.5	54	62	72	87	102	127	147	167
L8	66	72.5	85	95	116.5	133.5	161.5	181.5	205
L11	27	30	36	44	55	67	85	95	110
L13	13	15	15	15	15	15	20	25	25
L21	75	84.5	99	122	144.5	157.5	206.5	239	248
L22	107.5	122	144	177	214.5	242.5	311.5	359	388
L23	15	15	20	20	26	28	31	31	32.5
L24	15	15	20	20	26	28	31	31	32.5
L25	15	15	19.5	19.5	25.5	27.5	30.5	30.5	32.5
L26	18.5	18.5	23	23	29.5	31.5	34.5	34.5	38
C1 ¹³	46	46	70	100	100	100	130	165	165
C2 ¹³	M4	M4	M5	M6	M6	M6	M8	M10	M10
C3 ¹³	≤12	≤12	≤16	≤24	≤24	≤24	≤32	≤38	≤38
C4 ¹³	30	30	34	40	40	40	50	60	60
C5 ¹³	30	30	50	80	80	80	110	130	130
C6 ¹³	3.5	3.5	8	4	4	4	5	6	6
C7 ¹³	42	42	60	92	92	92	115	142	142
C8 ¹³	21.5	21.5	21.5	20	20	20	24	31	31
C9 ¹³	161.5	181	210.5	252	304.5	347.5	440.5	510	559
C10 ¹³	14.5	14.5	15.5	13	13	13	16	21	21

13. C1-C10 是公制標準馬達連接板之尺寸, 請上網點選"減速機選用"找出正確之尺寸。

AT-FC系列孔輸出帶抱箍

Hole Output Hoop Type

尺寸 (三節 3-stage, 減速比ratio i=75~500)



外形尺寸圖 Dimensions:

Unit:mm

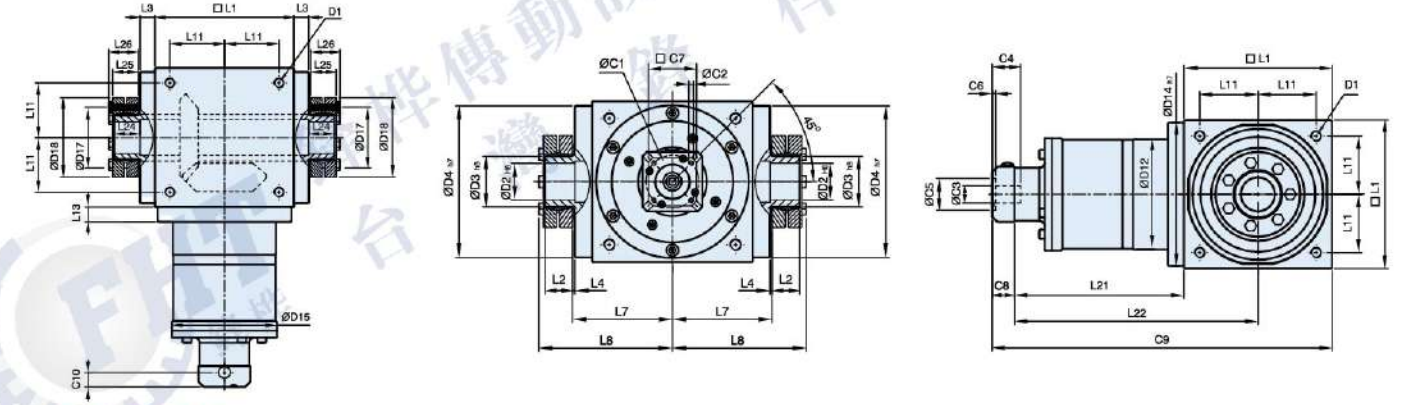

● 標準配件含 2 個縮緊盤

規格表 Specifications:

Unit:mm

尺寸 Sizes	AT110FC	AT140FC	AT170FC	AT210FC	AT240FC	AT280FC
D1	M8	M10	M12	M16	M16	M16
D2 H6	22	32	40	50	55	60
D3 h8	25	44	50	62	68	75
D4 h7	108	135	165	205	235	275
D12	106	104	128	160	180	200
D14 h7	108	135	165	205	235	275
D15	107	106	127	158	178	198
D17	38	61	70	86	86	100
D18	50	80	90	110	115	138
L1	110	140	170	210	240	280
L2	18	24	26	29	29	30.5
L3	15	15	15	20	25	25
L4	2	2	2	2	2	2
L7	72	87	102	127	147	167
L8	95	116.5	133.5	161.5	181.5	205
L11	44	55	67	85	95	110
L13	15	15	15	20	25	25
L21	136.5	159.5	183.5	226	269	278
L22	191.5	229.5	268.5	331	389	418
L23	20	26	28	31	31	32.5
L24	20	26	28	31	31	32.5
L25	19.5	25.5	27.5	30.5	30.5	32.5
L26	23	29.5	31.5	34.5	34.5	38
C1 ¹⁴	46	46	70	100	100	100
C2 ¹⁴	M4	M4	M5	M5	M6	M6
C3 ¹⁴	≤12	≤12	≤16	≤16	≤24	≤24
C4 ¹⁴	30	30	34	34	40	40
C5 ¹⁴	30	30	50	50	80	80
C6 ¹⁴	3.5	3.5	8	8	4	4
C7 ¹⁴	42	42	60	60	92	92
C8 ¹⁴	21.5	21.5	21.5	21.5	20	20
C9 ¹⁴	268	321	375	457.5	529	578
C10 ¹⁴	14.5	14.5	15.5	15.5	13	13

14. C1-C10 是公制標準馬達連接板之尺寸, 請上網點選"減速機選用"找出正確之尺寸。

轉向圖 Diagram of Rotate Direction

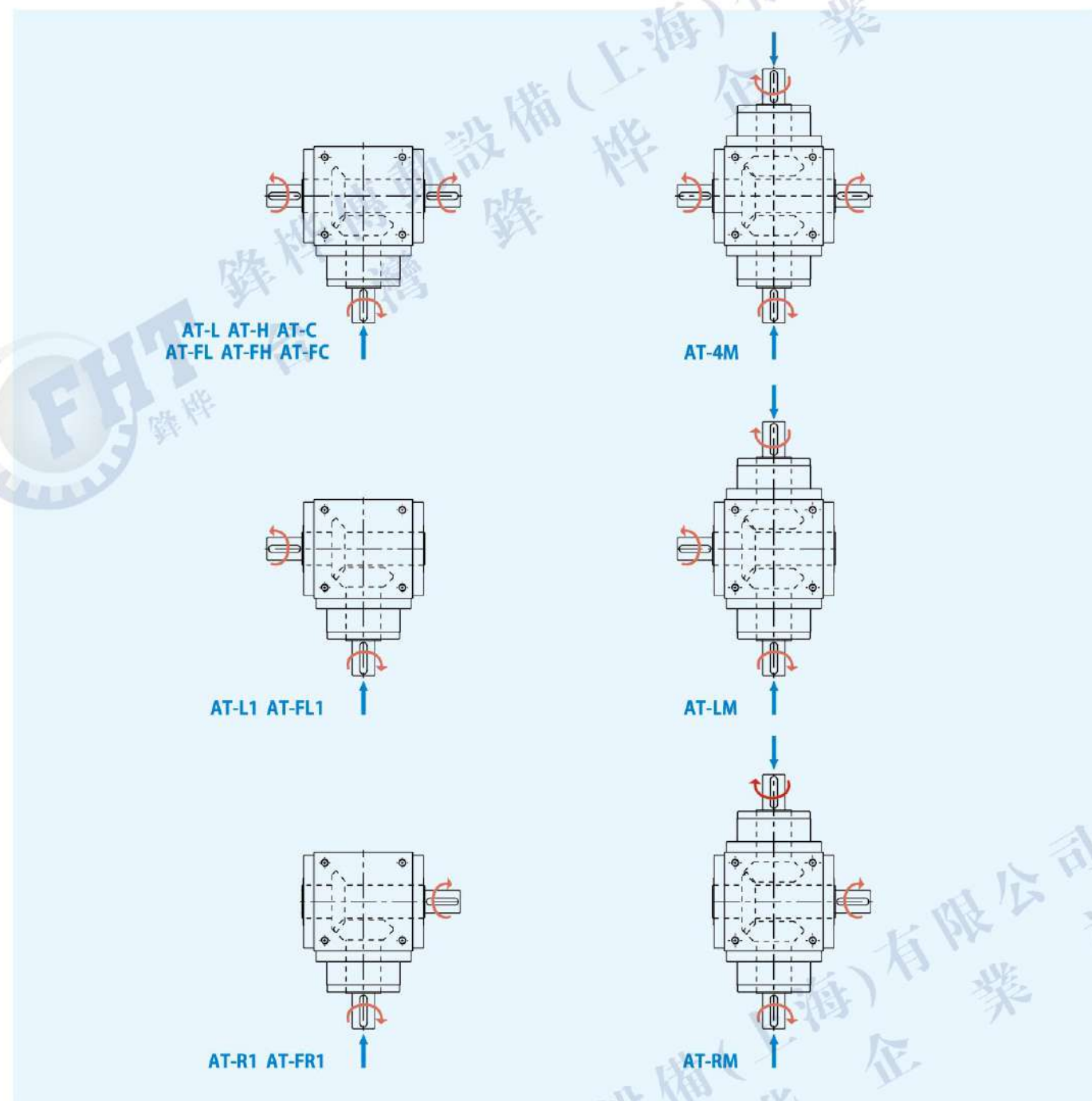

適用於多軸連動場合：

TFT-LCD 升降機構、各種升降、水平連動機構... 等機構

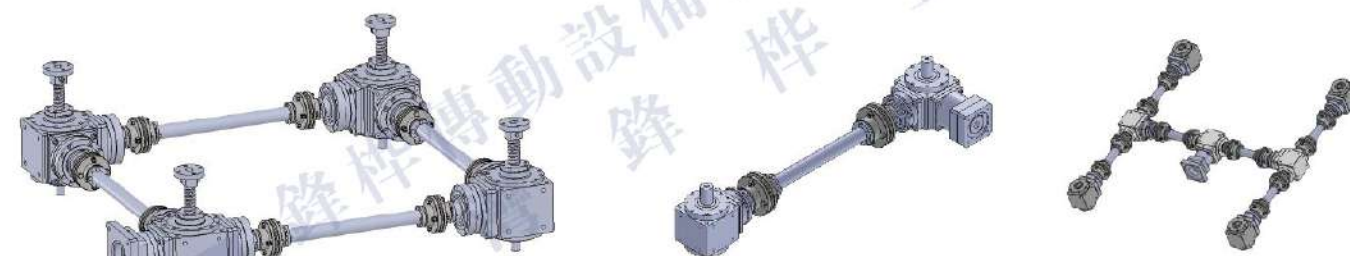

減速機-背隙測定值：

入力軸固定,出力軸施以微小力距(額定值的5%),測量棒往左再往右測得的 θ° ($+\theta^\circ$ 與 $-\theta^\circ$)即為背隙。

背隙值的計算：

例:當 360° 裡最大 θ° 為 0.05° (3弧分),半徑500MM,背隙值等於
 $(500 * 2 * \pi) \div (360 * 60) * 3 = 0.436\text{MM}$

θ° 為 0.05° (3弧分)= 0.436MM (背隙值或齒隙)

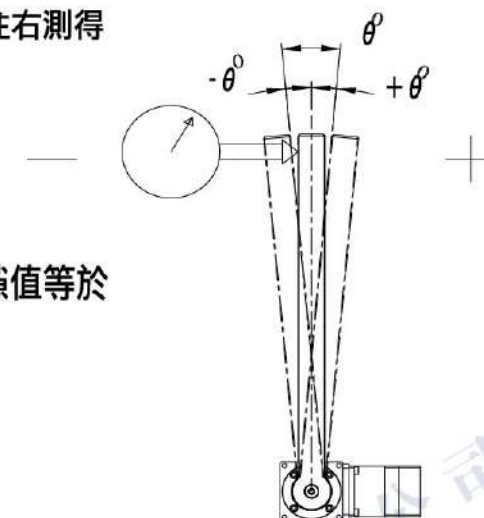

減速機-出力軸偏擺與同心度

- 1.輸出軸的偏擺與同心度的高低對其壽命有絕對的影響,出力軸偏擺過大易產生偏擺運動,對齒輪產生磨損壽命縮短。
- 2.全系列使用NSK錐形滾柱軸承,軸偏擺要求 0.01MM 以內(測量時施以定格扭距的5%)。

縮緊盤附件選配 Selection of Shrink Disc Accessories

(單位: mm)

C / FC 系列	D1	D2	D3	H1	H2
SSD-d16xdw14	41	16	26	15	18.5
SSD-d22xdw18	50	22	36	19.5	23
SSD-d25xdw22	50	25	38	19.5	23
SSD-d44xdw32	80	44	61	25.5	29.5
SSD-d50xdw40	90	50	70	27.5	31.5
SSD-d62xdw50	110	62	86	30.5	34.5
SSD-d68xdw55	115	68	86	30.5	34.5
SSD-d75xdw60	138	75	100	32.5	38

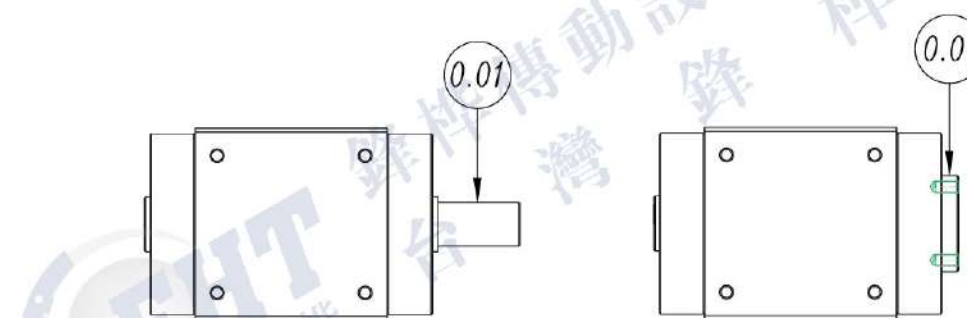

PAW-A(B) / PT系列

90度精密減速機

90 Degree Precision Speed Reducer

多種輸出軸型式 減速機1:1-1:100

Multiple Output Shaft Type Reducer 1:1-1:100

適用之伺服馬達容量: 0.1kw-15kw

Applicable Servo Motor Capacity: 0.1kw-15kw



1. 中空軸+錐形迫緊環：適用於大負荷場合。
2. 適用：滾輪機構、輸送搬運機構、凸輪機構、液晶面板翻轉機構、齒條齒輪機構等任何產業之機構。

1. 中空軸旋轉法蘭：適用於大負荷場合。
2. 適用：旋轉機構、CNC車床機械手臂之翻轉機構。



1. 中空軸(夾緊式)，單中空軸與雙中空軸。
2. 適用：輸送搬運機構。

1. 中空軸夾緊式加鍵槽：適用大負荷場合。
2. 適用：滾輪機構、輸送搬運機構、凸輪機構、液晶面板翻轉機構、齒條齒輪機構。



1. 中空軸有鍵槽：新型追加止付牙孔。
2. 一般輸送機構。

轉向器

型號說明 Model Description

PAW-A(B)系列: PAW055A~PAW180A(B)

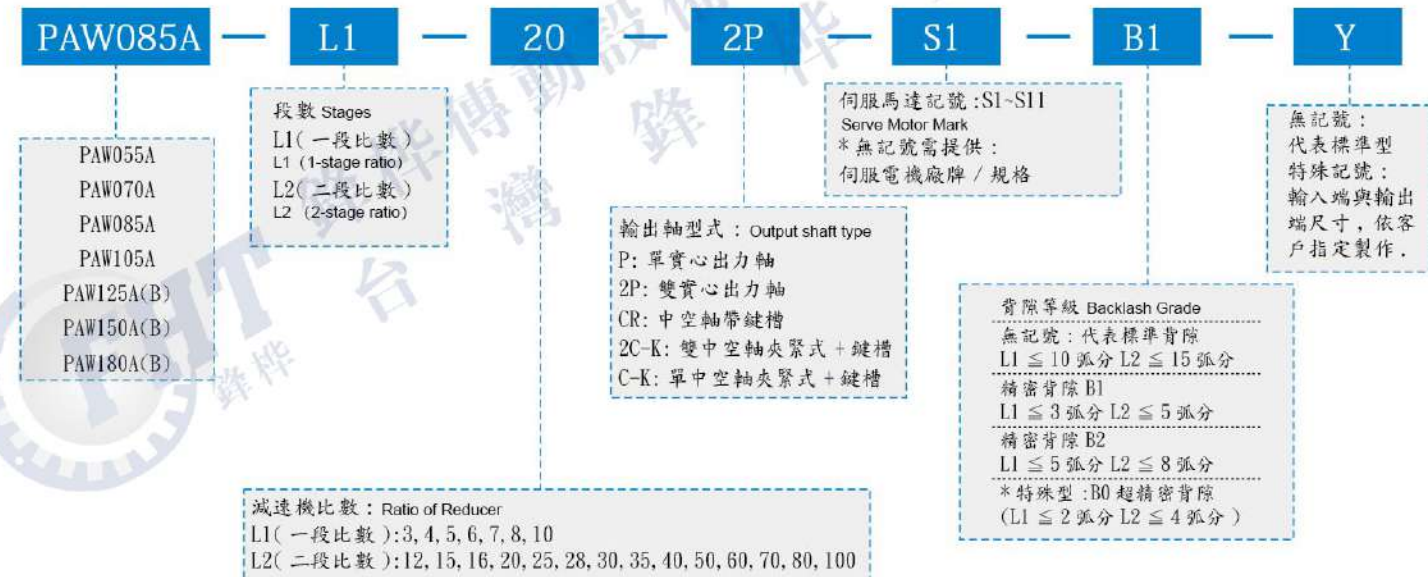

型號說明 Model Description

PT系列: PT070A~PT180B

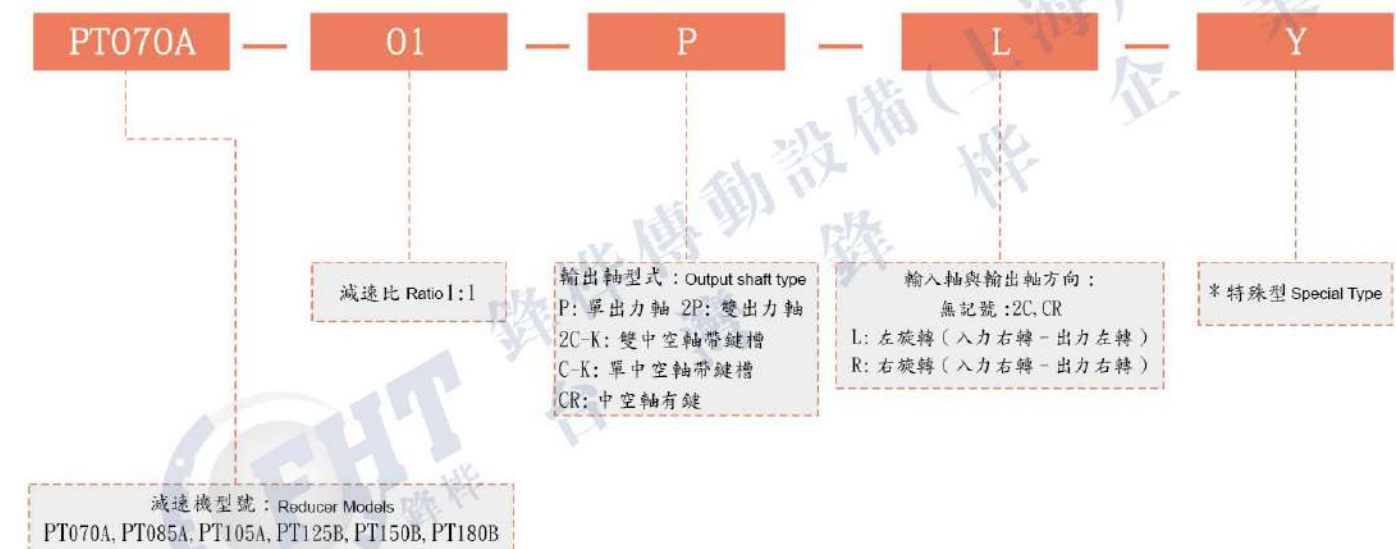

PAW-A(B) / PT系列-性能参数表

Performance Parameters Table

規格 Specification	段數 Stages	減速比 (i) Ratio	PAW055A	PAW070A PT070A	PAW085A PT085A	PAW105A PT105A	PAW125A PT125B	PAW125B	PAW150A PT150B	PAW150B	PAW180A	PAW180B PT180B
額定輸出轉距(Nm) Rated Output Torque	一段 L1	1/1		30	40	100	230		400			600
		1/3	10	30	40	100	230	100	400	230	900	450
		1/4	15	30	50	150	250	160	500	330	1100	550
		1/5	15	30	50	150	250	160	500	330	1200	550
		1/6	14	30	42	120	230	160	500	290	1100	530
		1/7	14	30	42	120	230	160	500	290	1100	530
		1/10	10	30	40	100	230	100	400	230	900	450
	二段 L2	1/12	10	30	40	100	230	100	400	230	900	450
		1/15	10	30	40	100	230	100	400	230	900	450
		1/16	15	30	50	150	250	160	500	330	1200	550
		1/20	15	30	50	150	250	160	500	330	1200	550
		1/25	15	30	50	150	250	160	500	330	1200	550
		1/28	15	30	50	150	250	160	500	330	1100	550
		1/30	10	30	40	100	230	100	450	330	900	450
1/35		15	30	50	150	250	160	500	330	1100	550	
1/40		15	30	50	150	250	160	500	330	1100	550	
1/50		15	30	50	150	250	160	500	330	1100	550	
1/60		15	30	50	150	250	160	500	330	1100	550	
1/70		12	30	50	120	250	160	500	290	1100	550	
1/100		10	30	40	100	230	100	400	230	900	450	
最大輸出轉距 (Nm) Max. Output Torque		L1, L2	3~100	3倍額定輸出轉距(Nm) 3 Times of Rated Output Torque								
輸入轉速 (rpm) Input Speed	L1, L2	3~100	3000	3000	3000	3000	3000	3000	3000	3000	3000	3000
標準背隙 (arc-min) Standard Backlash	L1	3~10	≤10	≤10	≤10	≤10	≤10	≤10	≤10	≤10	≤10	≤10
	L2	12~100	≤15	≤15	≤15	≤15	≤15	≤15	≤15	≤15	≤15	≤15
精密背隙 B2 (arc-min) Precision Backlash	L1	3~10	≤5	≤5	≤5	≤5	≤5	≤5	≤5	≤5	≤5	≤5
	L2	12~100	≤8	≤8	≤8	≤8	≤8	≤8	≤8	≤8	≤8	≤8
精密背隙 B1 (arc-min) Precision Backlash	L1	3~10	≤3	≤3	≤3	≤3	≤3	≤3	≤3	≤3	≤3	≤3
	L2	12~100	≤5	≤5	≤5	≤5	≤5	≤5	≤5	≤5	≤5	≤5
容許徑向力 (N) Radial	L1, L2	3~100	1100	3250	3250	5850	9100	9100	14300	14300	19500	19500
容許軸向力 (N) Axial	L1, L2	3~100	650	3250	3250	5850	9100	9100	14300	14300	19500	19500
效率 (%) Efficiency	L1	3~10	90%									
	L2	12~100	85%									
重量 (kg) Weight	L1	3~10	1.8	2.9	3.8	10.5	15.5	12.5	31	25.5	56.5	37.5
	L2	12~100	2.1	3.3	4.3	11.2	17	13.2	35.5	28.5	63.5	42.0
使用溫度 (°C) Temperature	L1, L2	3~100	-10°C~+80°C									
潤滑油 Lubrication oil	L1, L2	3~100	全合成潤滑油 (COMPLEX HV2) Fully Synthetic Grease									
安裝方向 Installation Direction	L1, L2	3~100	任意方向 Any Installation Direction									
噪音值 (db) Noise value	L1, L2	3~100	≤68	≤68	≤68	≤68	≤70	≤70	≤72	≤72	≤74	≤74

*1/1, 入力轉速需≤1500 RPM以內。

* 入力軸與法蘭詳細尺寸 C1~C7, 如頁數 38P

PAW系列-2P雙出力軸型式 Double Output Shaft Type

*PAW055A~PAW180A: 減速比 Ratio (1/3~1/100)



外形尺寸圖 Dimensions:

Unit:mm

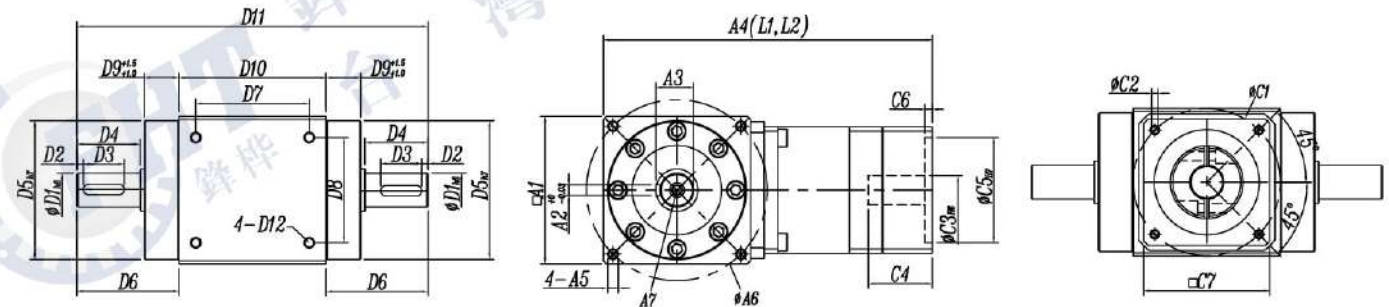

規格表 Specifications:

Unit:mm

規格	PAW055A	PAW070A	PAW085A	PAW105A	PAW125A	PAW125B	PAW150A	PAW150B	PAW180A	PAW180B
A1	55	70	85	105	125	125	150	150	180	180
A2	4	5	6	8	10	10	12	12	14	14
A3	14.5	18	22.5	31	35	35	43	43	53.5	53.5
A4 (L1單段)	127.5	157	173	223	281	247.5	368	312	403	368
A4 (L2雙段)	153	178	194	250	308.5	274.5	414	340	455	414
A5	M5-10L	M5-12L	M6-12L	M8-15L	M8-15L	M8-15L	M10-18L	M10-18L	M12-18L	M12-18L
A6	65	86	100	118	145	145	185	185	200	200
A7	M4	M5	M6	M8	M8	M8	M12	M12	M12	M12
D1	13	16	20	28	32	32	40	40	50	50
D2	3	3	3.5	3	3	3	3	3	3	3
D3	20	20	25	30	40	40	50	50	60	60
D4	26	30	35	40	50	50	63	63	73	73
D5	53.5	66	82	100	120	120	135	135	165	165
D6	40.25	48.5	52.5	60.5	71.5	71.5	85	85	96	96
D7	45	54	68	80	100	100	120	120	141.4	141.4
D8	34	50	52	60	80	80	100	100	141.4	141.4
D9	12.75	16.5	15.5	18.5	19.5	19.5	20	20	21	21
D10	55	70	85	105	125	125	150	150	180	180
D11	135.5	167	190	226	268	268	320	320	372	372
D12	M5-10L	M5-12L	M6-12L	M8-15L	M8-15L	M8-15L	M10-18L	M10-18L	M12-18L	M12-18L
C1	≤70	≤90	≤90	≤145	≤200	≤145	≤215	≤200	≤215	≤215
C2	≤M4	≤M6	≤M6	≤M8	≤M12	≤M8	≤M12	≤M12	≤M12	≤M12
C3	≤11	≤19	≤19	≤24	≤35	≤24	≤42	≤35	≤42	≤42
C4	≤30	≤41	≤41	≤62	≤80	≤62	≤116	≤80	≤116	≤116
C5	≤50	≤70	≤70	≤110	≤114.3	≤110	≤180	≤114.3	≤180	≤180
C6	≤3.5	≤5	≤5	≤7	≤7	≤7	≤7	≤7	≤7	≤7
C7	≤60	≤80	≤80	≤120	≤176	≤120	≤196	≤176	≤220	≤176

* 入力軸與法蘭詳細尺寸 C1~C7, 如頁數 38P

PAW系列-P單出力軸型式

Single Output Shaft Type

*PAW070A~~PAW180A:減速比Ratio(1/3~~1/100)



外形尺寸圖 Dimensions:

Unit:mm

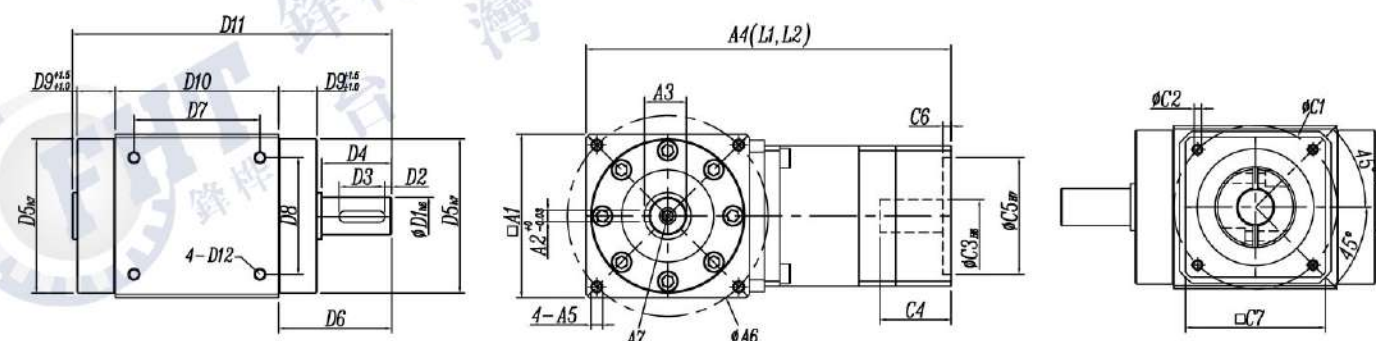

規格表 Specifications:

Unit:mm

規格	PAW055A	PAW070A	PAW085A	PAW105A	PAW125A	PAW125B	PAW150A	PAW150B	PAW180A	PAW180B
A1	55	70	85	105	125	125	150	150	180	180
A2	4	5	6	8	10	10	12	12	14	14
A3	14.5	18	22.5	31	35	35	43	43	53.5	53.5
A4 (L1單段)	127.5	157	173	223	281	247.5	368	312	403	368
A4 (L2雙段)	153	178	194	250	308.5	274.5	414	340	455	414
A5	M5-10L	M5-12L	M6-12L	M8-15L	M8-15L	M8-15L	M10-18L	M10-18L	M12-18L	M12-18L
A6	65	86	100	118	145	145	185	185	200	200
A7	M4	M5	M6	M8	M8	M8	M12	M12	M12	M12
D1	13	16	20	28	32	32	40	40	50	50
D2	3	3	3.5	3	3	3	3	3	3	3
D3	20	20	25	30	40	40	50	50	60	60
D4	26	30	35	40	50	50	63	63	73	73
D5	53.5	66	82	100	120	120	135	135	165	165
D6	40.25	48.5	52.5	60.5	71.5	71.5	85	85	96	96
D7	45	54	68	80	100	100	120	120	141.4	141.4
D8	34	50	52	60	80	80	100	100	141.4	141.4
D9	12.75	16.5	15.5	18.5	19.5	19.5	20	20	21	21
D10	55	70	85	105	125	125	150	150	180	180
D11	109.5	137	155	186	218	218	257	257	299	299
D12	M5-10L	M5-12L	M6-12L	M8-15L	M8-15L	M8-15L	M10-18L	M10-18L	M12-18L	M12-18L
C1	≤70	≤90	≤90	≤145	≤200	≤145	≤215	≤200	≤215	≤215
C2	≤M4	≤M6	≤M6	≤M8	≤M12	≤M8	≤M12	≤M12	≤M12	≤M12
C3	≤11	≤19	≤19	≤24	≤35	≤24	≤42	≤35	≤42	≤42
C4	≤30	≤41	≤41	≤62	≤80	≤62	≤116	≤80	≤116	≤116
C5	≤50	≤70	≤70	≤110	≤114.3	≤110	≤180	≤114.3	≤180	≤180
C6	≤3.5	≤5	≤5	≤7	≤7	≤7	≤7	≤7	≤7	≤7
C7	≤60	≤80	≤80	≤120	≤176	≤120	≤196	≤176	≤220	≤176

* 入力軸與法蘭詳細尺寸 C1~C7, 如頁數 38P

PAW系列-2C-K 雙中空軸帶鍵型式

Double Hollow Shaft Key Groove Type

*PAW070A~~PAW180A:減速比Ratio(1/3~~1/100)



外形尺寸圖 Dimensions:

Unit:mm

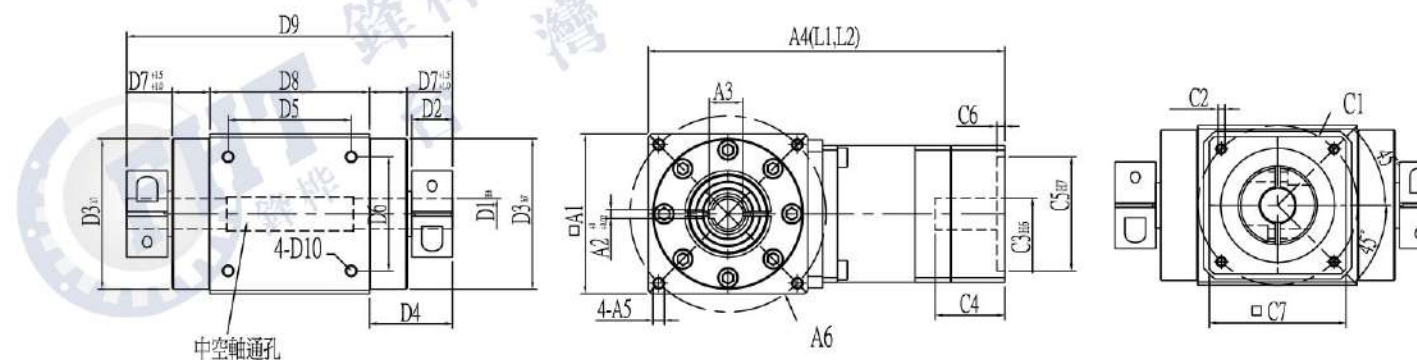

規格表 Specifications:

Unit:mm

規格	PAW070A	PAW085A	PAW105A	PAW125A	PAW125B	PAW150A	PAW150B	PAW180A	PAW180B
A1	70	85	105	125	125	150	150	180	180
A2	4	5	6	8	8	10	10	14	14
A3	14.7	16.3	24.7	31.3	31.3	38.3	38.3	53.8	53.8
A4 (L1單段)	157	173	223	281	247.5	368	312	403	368
A4 (L2雙段)	178	194	250	308.5	274.5	414	340	455	414
A5	M5-12L	M6-12L	M8-15L	M8-15L	M8-15L	M10-18L	M10-18L	M12-18L	M12-18L
A6	86	100	118	145	145	185	185	200	200
D1	13	15	22	28	28	35	35	50	50
D2	18	24	25	24	24	33	33	36.5	36.5
D3	66	82	100	120	120	135	135	165	165
D4	36.5	41.5	45.5	45.5	45.5	55	55	59.5	59.5
D5	54	68	80	100	100	120	120	141.4	141.4
D6	50	52	60	80	80	100	100	141.4	141.4
D7	16.5	15.5	18.5	19.5	19.5	20	20	21	21
D8	70	85	105	125	125	150	150	180	180
D9	143	168	196	216	216	260	260	299	299
D10	M5-12L	M6-12L	M8-15L	M8-15L	M8-15L	M10-18L	M10-18L	M12-18L	M12-18L
C1	≤90	≤90	≤145	≤200	≤145	≤215	≤200	≤215	≤215
C2	≤M6	≤M6	≤M8	≤M12	≤M8	≤M12	≤M12	≤M12	≤M12
C3	≤19	≤19	≤24	≤35	≤24	≤42	≤35	≤42	≤42
C4	≤41	≤41	≤62	≤80	≤62	≤116	≤80	≤116	≤116
C5	≤70	≤70	≤110	≤114.3	≤110	≤180	≤114.3	≤180	≤180
C6	≤5	≤5	≤7	≤7	≤7	≤7	≤7	≤7	≤7
C7	≤80	≤80	≤120	≤176	≤120	≤196	≤176	≤220	≤176

* 入力軸與法蘭詳細尺寸 C1~C7, 如頁數 38P

PAW系列-C-K 單中空軸帶鍵型式

Single Hollow Shaft Key Groove Type

*PAW070A~~PAW180A減速比Ratio(1/3~~1/100)



外形尺寸圖 Dimensions:

Unit:mm

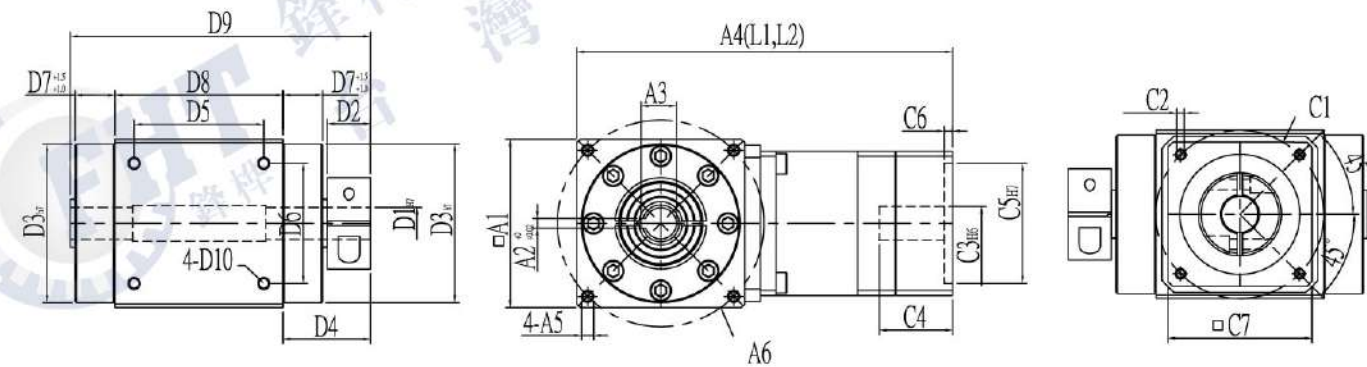

規格表 Specifications:

Unit:mm

規格	PAW070A	PAW085A	PAW105A	PAW125A	PAW125B	PAW150A	PAW150B	PAW180A	PAW180B
A1	70	85	105	125	125	150	150	180	180
A2	4	5	6	8	8	10	10	14	14
A3	14.7	16.3	24.7	31.3	31.3	38.3	38.3	53.8	53.8
A4 (L1單段)	157	173	223	281	247.5	368	312	403	368
A4 (L2雙段)	178	194	250	308.5	274.5	414	340	455	414
A5	M5-12L	M6-12L	M8-15L	M8-15L	M8-15L	M10-18L	M10-18L	M12-18L	M12-18L
A6	86	100	118	145	145	185	185	200	200
D1	13	15	22	28	28	35	35	50	50
D2	18	24	25	24	24	33	33	36.5	36.5
D3	66	82	100	120	120	135	135	165	165
D4	36.5	41.5	45.5	45.5	45.5	55	55	59.5	59.5
D5	54	68	80	100	100	120	120	141.4	141.4
D6	50	52	60	80	80	100	100	141.4	141.4
D7	16.5	15.5	18.5	19.5	19.5	20	20	21	21
D8	70	85	105	125	125	150	150	180	180
D9	125	144	171	192	192	227	227	262.5	262.5
D10	M5-12L	M6-12L	M8-15L	M8-15L	M8-15L	M10-18L	M10-18L	M12-18L	M12-18L
C1	≤90	≤90	≤145	≤200	≤145	≤215	≤200	≤215	≤215
C2	≤M6	≤M6	≤M8	≤M12	≤M8	≤M12	≤M12	≤M12	≤M12
C3	≤19	≤19	≤24	≤35	≤24	≤42	≤35	≤42	≤42
C4	≤41	≤41	≤62	≤80	≤62	≤116	≤80	≤116	≤116
C5	≤70	≤70	≤110	≤114.3	≤110	≤180	≤114.3	≤180	≤180
C6	≤5	≤5	≤7	≤7	≤7	≤7	≤7	≤7	≤7
C7	≤80	≤80	≤120	≤176	≤120	≤196	≤176	≤220	≤176

* 入力軸與法蘭詳細尺寸 C1~C7, 如頁數 38P

PAW系列-CR 中空軸帶鍵型式

Hollow Shaft Key Groove Type

*PAW070A~~PAW180A:減速比Ratio(1/3~~1/100)



外形尺寸圖 Dimensions:

Unit:mm

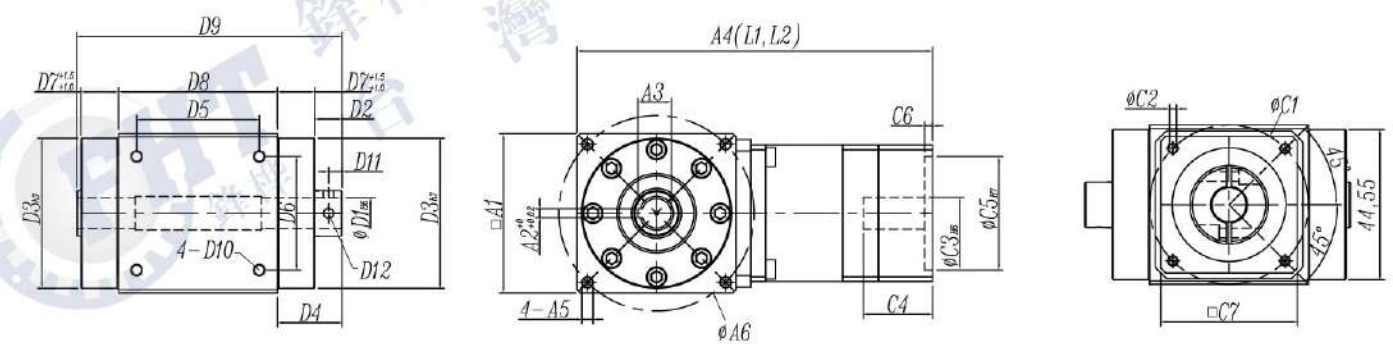

規格表 Specifications:

Unit:mm

規格	PAW070A	PAW085A	PAW105A	PAW125A	PAW125B	PAW150A	PAW150B	PAW180A	PAW180B
A1	70	85	105	125	125	150	150	180	180
A2	4	5	6	8	8	10	10	14	14
A3	14.7	17.3	24.7	31.3	31.3	38.3	38.3	53.8	53.8
A4 (L1單段)	156.5	173	223	281	247.5	368	312	403	368
A4 (L2雙段)	177.5	194	250	308.5	274.5	414	340	455	414
A5	M5-12L	M6-12L	M8-15L	M8-15L	M8-15L	M10-18L	M10-18L	M12-18L	M12-18L
A6	86	100	118	145	145	185	185	200	200
D1	13	15	22	28	28	35	35	50	50
D2	10	10	10	12	12	14	14	18	18
D3	66	82	100	120	120	135	135	165	165
D4	26.5	25.5	28.5	31.5	31.5	34	34	39	39
D5	54	68	80	100	100	120	120	141.4	141.4
D6	50	52	60	80	80	100	100	141.4	141.4
D7	16.5	15.5	18.5	19.5	19.5	20	20	21	21
D8	70	85	105	125	125	150	150	180	180
D9	125	144	171	192	192	227	227	262.5	262.5
D10	M5-12L	M6-12L	M8-15L	M8-15L	M8-15L	M10-18L	M10-18L	M12-18L	M12-18L
D11	5	5	5	6	6	7	7	9	9
D12	2-M4	2-M4	2-M5	2-M6	2-M6	2-M8	2-M8	2-M12	2-M12
C1	≤90	≤90	≤145	≤200	≤145	≤215	≤200	≤215	≤215
C2	≤M6	≤M6	≤M8	≤M12	≤M8	≤M12	≤M12	≤M12	≤M12
C3	≤19	≤19	≤24	≤35	≤24	≤42	≤35	≤42	≤42
C4	≤41	≤41	≤62	≤80	≤62	≤116	≤80	≤116	≤116
C5	≤70	≤70	≤110	≤114.3	≤110	≤180	≤114.3	≤180	≤180
C6	≤5	≤5	≤7	≤7	≤7	≤7	≤7	≤7	≤7
C7	≤80	≤80	≤120	≤176	≤120	≤196	≤176	≤220	≤176

* 入力軸與法蘭詳細尺寸 C1~C7, 如頁數 38P

PT系列-CR中空軸帶鍵槽型式

Hollow Shaft Key Groove Type

*轉向器Steering gear PT070A~PT180B, 速比 Ratio 1:1

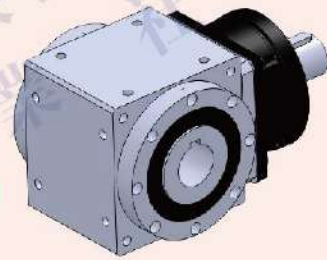

外形尺寸圖 Dimensions:

Unit:mm

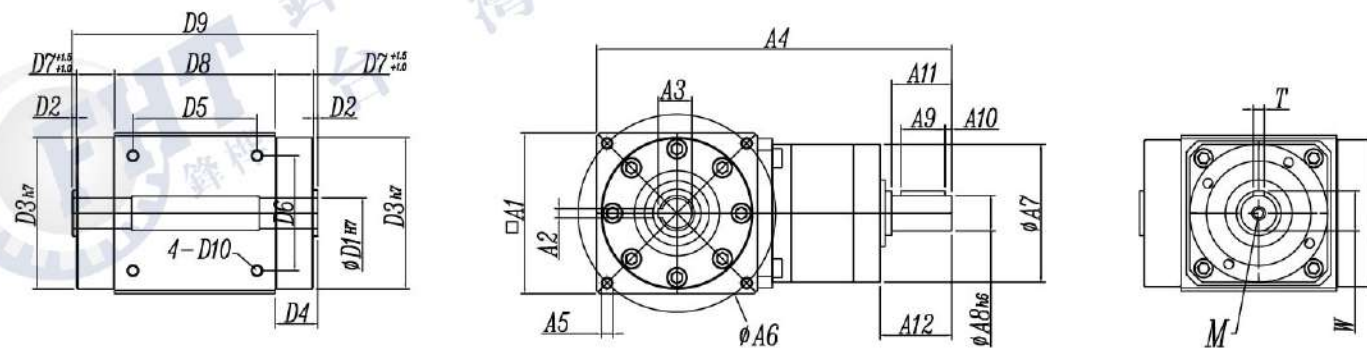

規格表 Specifications:

Unit:mm

規格	PT070A	PT085A	PT105A	PT125B	PT150B	PT180B
A1	70	85	105	125	150	180
A2	4	5	6	8	10	14
A3	14.7	17.3	24.7	31.3	38.3	53.8
A4	163.7	181.2	205	282.5	271.5	297
A5	4-M5-12L	4-M6-12L	4-M8-15L	4-M8-15L	4-M10-18L	4-M12-18L
A6	86	100	118	145	185	200
A7	62	62	90	120	142	142
A8	16	20	28	28	35	50
A9	20	20	30	30	40	60
A10	3	3	3	3	3	3
A11	27	27	34	34	45	65
A12	32.2	32.2	44	44	51.5	70
D1	13	15	22	28	35	50
D2	2	2	2	2	2	2
D3	66	82	100	120	135	165
D4	18.5	17.5	20.5	21.5	22	23
D5	54	68	80	100	120	141.4
D6	50	52	60	80	100	141.4
D7	16.5	15.5	18.5	19.5	20	21
D8	70	85	105	125	150	180
D9	107	120	146	168	194	226
D10	4-M5-12L	4-M6-12L	4-M8-15L	4-M8-15L	4-M10-18L	4-M12-18L
T	5	6	8	8	10	14
W	18	22.5	31	31	38	53.5
M	M5	M6	M8	M8	M10	M12

* 入力軸與法蘭詳細尺寸 C1~C7, 如頁數 38P

PT系列-2P雙出力軸型式

Double Output Shaft Type

*轉向器Steering gear PT070A~PT180B
減速Ratio比1:1



外形尺寸圖 Dimensions:

Unit:mm

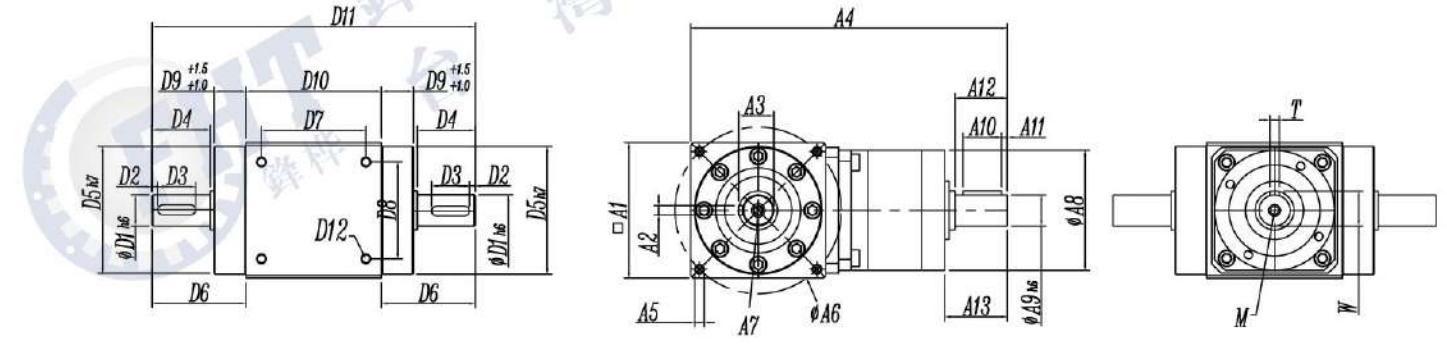

規格表 Specifications:

Unit:mm

規格	PT070A	PT085A	PT105A	PT125B	PT150B	PT180B
A1	70	85	105	125	150	180
A2	5	6	8	10	12	14
A3	18	22.5	31	35	43	53.5
A4	163.7	181.2	204.5	223	282.5	311
A5	4-M5-12L	4-M6-12L	4-M8-15L	4-M8-15L	4-M10-18L	4-M12-18L
A6	86	100	118	145	185	200
A7	M5	M6	M8	M8	M12	M12
A8	62	62	95	95	120	142
A9	16	20	28	28	35	50
A10	20	20	30	30	40	60
A11	3	3	3	3	3	3
A12	27	27	34	34	45	65
A13	32.2	32.2	44	44	51.5	70
D1	16	20	28	32	40	50
D2	3	3.5	3	3	3	3
D3	20	25	30	40	50	60
D4	30	35	40	50	63	73
D5	66	82	100	120	135	165
D6	48.5	52.5	60.5	71.5	85	96
D7	54	68	80	100	120	141.4
D8	50	52	60	80	100	141.4
D9	16.5	15.5	18.5	19.5	20	21
D10	70	85	105	125	150	180
D11	167	190	226	268	320	372
D12	4-M5-12L	4-M6-12L	4-M8-15L	4-M8-15L	4-M10-18L	4-M12-18L
T	5	6	8	8	10	14
W	18	22.5	31	31	38	53.5
M	M5	M6	M8	M8	M10	M12

* 入力軸與法蘭詳細尺寸 C1~C7, 如頁數 38P

PT系列-P單出力軸型式

Single Output Shaft Type

*轉向器PT070A~PT180B,減速比Ratio1:1



外形尺寸圖 Dimensions:

Unit:mm

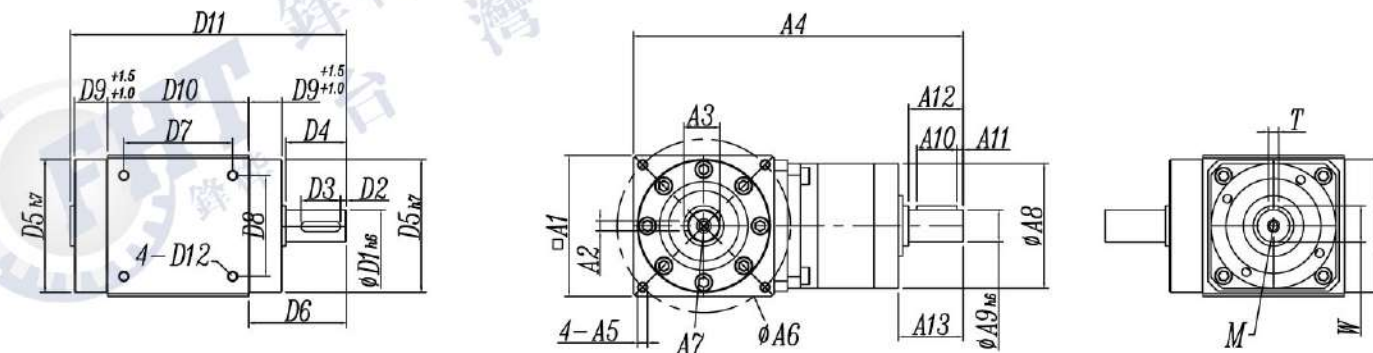

規格表 Specifications:

Unit:mm

規格	PT070B	PT085B	PT105B	PT125B	PT150B	PT180B
A1	70	85	105	125	150	180
A2	5	6	8	10	12	14
A3	18	22.5	31	35	43	53.5
A4	163.7	181.2	204.5	223	282.5	311
A5	4-M5-12L	4-M6-12L	4-M8-15L	4-M8-15L	4-M10-18L	4-M12-18L
A6	86	100	118	145	185	200
A7	M5	M6	M8	M8	M12	M12
A8	62	62	95	95	120	142
A9	16	20	28	28	35	50
A10	20	20	30	30	40	60
A11	3	3	3	3	3	3
A12	27	27	34	34	45	65
A13	32.2	32.2	44	44	51.5	70
D1	16	20	28	32	40	50
D2	3	3.5	3	3	3	3
D3	20	25	30	40	50	60
D4	30	35	40	50	63	73
D5	66	82	100	120	135	165
D6	48.5	52.5	60.5	71.5	85	96
D7	54	68	80	100	120	141.4
D8	50	52	60	80	100	141.4
D9	16.5	15.5	18.5	19.5	20	21
D10	70	85	105	125	150	180
D11	137	155	186	218	257	299
D12	M5-12L	M6-12L	M8-15L	M8-15L	M10-18L	M12-18L
T	5	6	8	8	10	14
W	18	22.5	31	31	38	53.5
M	M5	M6	M8	M8	M10	M12

* 入力軸與法蘭詳細尺寸 C1~C7, 如頁數 38P

PT系列-2C-K雙中空軸帶鍵槽型式

Double Hollow Shaft Key Groove Type

*轉向器PT070A~PT180B,減速比Ratio1:1

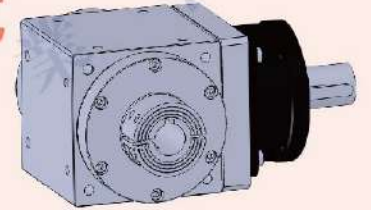

外形尺寸圖 Dimensions:

Unit:mm

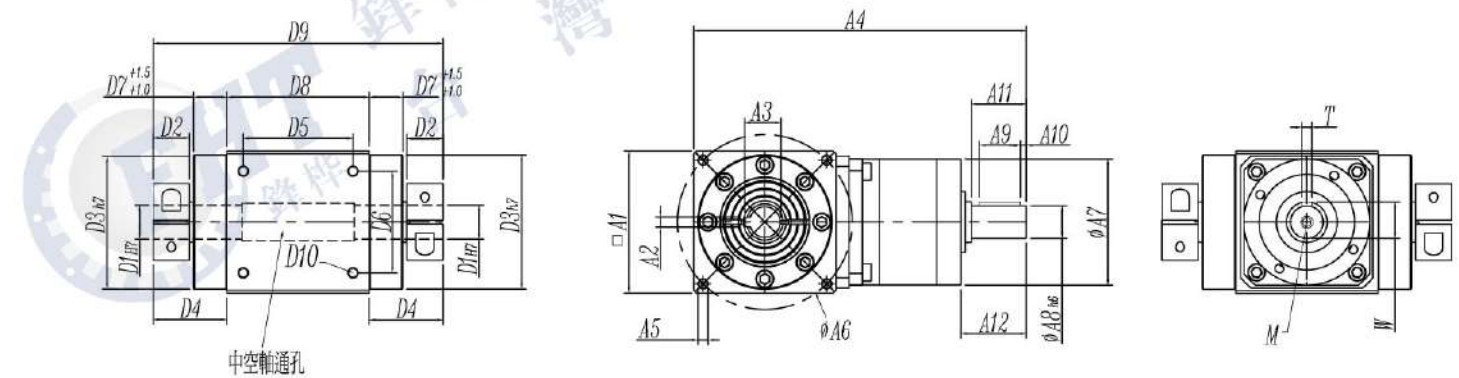

規格表 Specifications:

Unit:mm

規格	PT070A	PT085A	PT105A	PT125B	PT150B	PT180B
A1	70	85	105	125	150	180
A2	4	5	6	8	10	14
A3	14.7	17.3	24.7	31.3	38.3	53.5
A4	163.7	181.2	204.5	223	282.5	311
A5	4-M5-12L	4-M6-12L	4-M8-15L	4-M8-15L	4-M10-18L	4-M12-18L
A6	86	100	118	145	185	200
A7	62	62	95	95	120	142
A8	16	20	28	28	35	50
A9	20	20	30	30	40	60
A10	3	3	3	3	3	3
A11	27	27	34	34	45	65
A12	32.2	32.2	44	44	51.5	70
D1	13	15	22	28	35	50
D2	18	24	25	24	33	36.5
D3	66	82	100	120	135	165
D4	36.5	41.5	45.5	45.5	55	59.5
D5	54	68	80	100	120	141.4
D6	50	52	60	80	100	141.4
D7	16.5	15.5	18.5	19.5	20	21
D8	70	85	105	125	150	180
D9	107	120	146	168	194	226
D10	4-M5-12L	4-M6-12L	4-M8-15L	4-M8-15L	4-M10-18L	4-M12-18L
T	5	6	8	8	10	14
W	18	22.5	31	31	38	53.5
M	M5	M6	M8	M8	M10	M12

* 入力軸與法蘭詳細尺寸 C1~C7, 如頁數 38P

PT系列-C-K單中空軸帶鍵槽型式

Single Hollow Shaft Key Groove Type

*轉向器PT070A~PT180B,減速比Ratio1:1

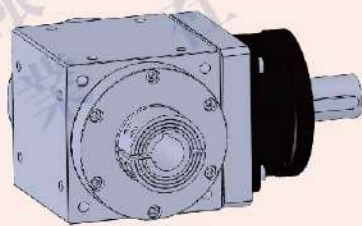

外形尺寸圖 Dimensions:

Unit:mm

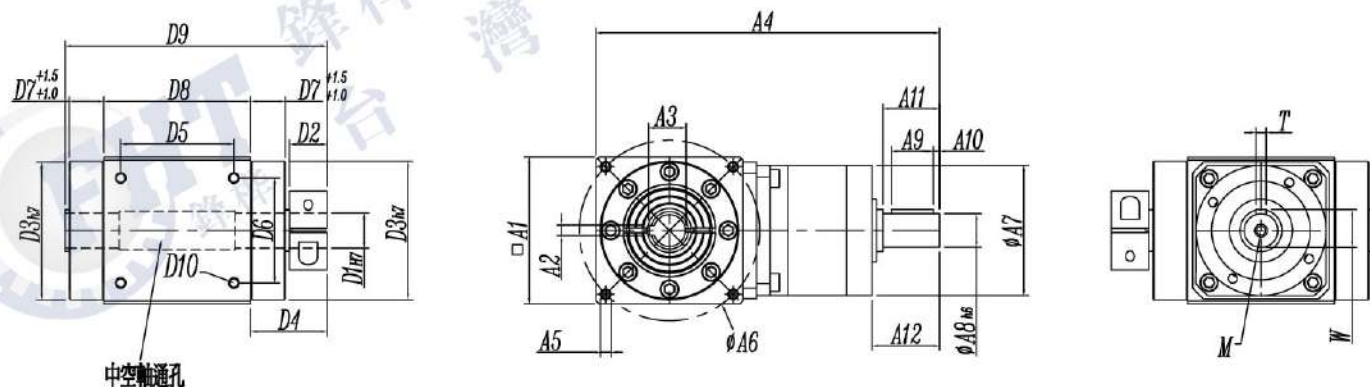

規格表 Specifications:

Unit:mm

規格	PT070A	PT085A	PT105A	PT125B	PT150B	PT180B
A1	70	85	105	125	150	180
A2	4	5	6	8	10	14
A3	14.7	17.3	24.7	31.3	38.3	53.5
A4	163.7	181.2	204.5	223	282.5	311
A5	4-M5-12L	4-M6-12L	4-M8-15L	4-M8-15L	4-M10-18L	4-M12-18L
A6	86	100	118	145	185	200
A7	62	62	95	95	120	142
A8	16	20	28	28	35	50
A9	20	20	30	30	40	60
A10	3	3	3	3	3	3
A11	27	27	34	34	45	65
A12	32.2	32.2	44	44	51.5	70
D1	13	15	22	28	35	50
D2	18	24	25	24	33	36.5
D3	66	82	100	120	135	165
D4	36.5	41.5	45.5	45.5	55	59.5
D5	54	68	80	100	120	141.4
D6	50	52	60	80	100	141.4
D7	16.5	15.5	18.5	19.5	20	21
D8	70	85	105	125	150	180
D9	89	96	121	144	161	189.5
D10	4-M5-12L	4-M6-12L	4-M8-15L	4-M8-15L	4-M10-18L	4-M12-18L
T	5	6	8	8	10	14
W	18	22.5	31	31	38	53.5
M	M5	M6	M8	M8	M10	M12

* 入力軸與法蘭詳細尺寸 C1~C7, 如頁數 38P

PAW-A(B) / PT系列 series

入力端詳細尺寸圖 Detailed Sizes Diagram of Input End

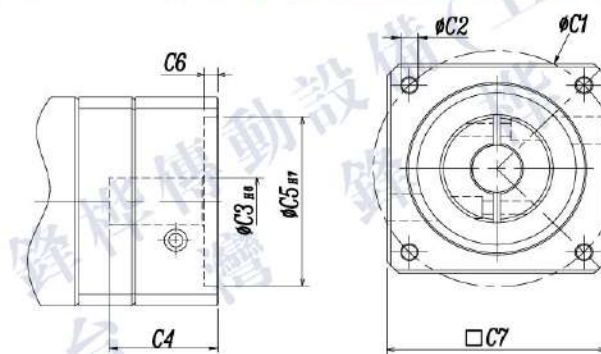

* 入力軸與法蘭詳細尺寸C1~C7.

* 馬達記號是指不同廠牌の入力端尺寸.

* 特製品:可依客戶指定製作入力法蘭尺寸.

型號	PAW055A								PAW070A/PAW085A								PAW105A							
尺寸	馬達記號	S1	S2	S1	S2	S3	S4	S5	S6	S7	S8	S1	S2	S3	S4	S5	S6	S7	S8	S9	S10	S11		
C1		45	46	45	46	70	70	70	90	90	66.7	70	70	70	90	90	90	100	145	145	145			
C2		M3	M4	M3	M4	M4	M4	M5	M5	M6	M4	M3	M4	M5	M5	M6	M6	M6	M6	M8	M8	M8		
C3 _{H6}		8	8	8	8	11	14	14	14	14	6.35	11	14	14	14	14	16	19	16	19	22	24		
C4		29	29	31	31	31	31	31	31	31	31	41	41	41	41	41	41	41	41	58	58	58		
C5 _{H7}		30	30	30	30	50	50	50	70	70	38.1	50	50	50	70	70	70	70	80	110	110	110		
C6		3.5	3.5	3.5	3.5	3.5	3.5	3.5	3.5	3.5	3.5	5	5	5	5	5	5	5	5	5	5	5		
C7		42	42	62	62	62	62	62	62	62	62	90	90	90	90	90	90	90	90	130	130	130		

型號	PAW125A/PAW150B										PAW150A/PAW180B								
尺寸	馬達記號	S1	S2	S3	S4	S5	S6	S7	S8	S9	S10	S1	S2	S3	S4	S5	S6	S7	S8
C1		90	90	100	115	115	130	145	145	145	145	115	115	145	145	145	145	200	165
C2		M6	M6	M6	M6	M8	M8	M8	M8	M8	M8	M6	M8	M8	M8	M8	M8	M12	M10
C3 _{H6}		16	19	16	24	24	19	19	22	24	28	24	24	19	22	24	28	35	32
C4		54	54	54	54	54	62	62	62	62	63	60	60	65	65	65	65	81	65
C5 _{H7}		70	70	80	95	95	110	110	110	110	95	95	110	110	110	110	110	114.3	130
C6		7	7	7	7	7	7	7	7	7	7	7	7	7	7	7	7	7	7
C7		120	120	120	120	120	120	120	120	120	120	142	142	142	142	142	142	176	142

型號	PAW180A											
尺寸	馬達記號	S1	S2	S3	S4	S5	S6	S7	S8	S9	S10	S11
C1		145	145	145	115	200	200	165	215	235	235	265
C2		M8	M8	M8	M6	M12	M12	M10	M12	M12	M12	M10
C3 _{H6}		19	22	24	28	35	42	32	38	42	55	55
C4		75	75	75	75	81	81	81	116	116	116	116
C5 _{H7}		110	110	110	110	114.3	114.3	130	180	200	200	230
C6		10	10	10	10	10	10	10	10	10	10	10
C7		180	180	180	180	180	180	180	192	220	220	220

* 入力軸與法蘭詳細尺寸 C1~C7, 如頁數 38P

AAW-AS(BS) / AAT(M)系列

90度精密減速機

90 Degree Precision Speed Reducer

多種輸出軸型式、減速比：1:2~1:500

Multiple Output Shaft Type Reduction Ratio 1:2-1:500

適用之伺服馬達容量：0.1kw~45kw

Applicable Servo Motor Capacity : 0.1kw-45kw



大型中空旋轉法蘭:適用於大負荷場合。
TFT-LCD 面板翻轉、旋轉機構、機械手臂底座
旋轉、擺臂旋轉、分度旋轉...等機構。



中空軸迫緊環:適用於大負荷場合。
滾輪機構、凸輪機構、輸送搬運...等機構。



出口軸型:適用於大負荷場合。
聯軸機構、皮帶輸送...等機構。



螺桿減速機:適用於直線運動場合。
垂直、水平之直線運動...等機構。

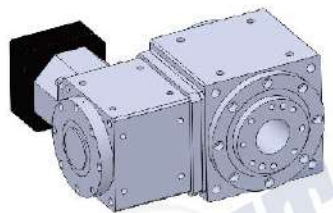

中空旋轉平台:適用於大負荷場合。
TFT-LCD 面板翻轉、分度盤機構...等機構



转向器

AAW-AS(BS) / AAT(M)系列-性能表:

Performance table

規格 Specification	段數 Stage	減速比 (i) Ratio	AAW070AS	AAW080AS AAT080AS AAW080AS-HR	AAW100AS AAT100AS AAW100AS-HR	AAW135AS AAT135AS AAW135AS-HR	AAW165AS AAT165AS AAW165AS-HR	AAW200AS	AAW200BS AAT200BS AAW200BS-HR	AAW320AS AAT320AS-HR	AAW320BS			
額定輸出 轉距 (Nm) Rated Output Torque	一段 1-stage L1	1/2,1/3,1/5,1/10	30	80	250	450	800	2000	3500					
		1/6		80	200	400	280	700	600	1500	1000	3500		
		1/8		85	250	450	320	800	660	1850	1100	4000		
		1/10		85	250	450	320	800	660	1850	1100	4000		
		1/12		80	225	435	320	750	660	1850	1100	4000		
		1/14		80	215	425	280	750	600	1750	1000	3500		
	二段 2-stage L2	1/16		80	210	415	270	700	600	1700	1000			
		1/20	30	70	200	400	240	700	460	1650	900	3000		
		1/30	30	80	200	400	280	700	600	1500	1000	3500		
		1/32		85	250	450	320	800	660	1850	1100	4000		
		1/40	30	85	250	450	320	800	660	1850	1100	4000		
		1/50	30	85	250	450	320	800	660	1850	1100	4000		
		1/56		85	250	450	320	800	660	1850	1100	3500		
		1/60		80	200	400	280	700	600	1500	1000	3500		
		1/70	30	85	250	450	320	800	660	1850	1100	3500		
		1/80		85	250	450	320	800	660	1850	1100	3500		
最大輸出 轉距 (Nm)	L1, L2	3~100	2.5倍額定輸出轉距 (Nm) 2.5 Times of Rated Output Torque											
		輸入轉速 (rpm)	L1, L2	3~100	3000	3000	3000	3000	3000	3000	3000	3000	3000	3000
		標準背隙 (arc-min)	L1	3~10	≤5	≤5	≤5	≤5	≤5	≤5	≤5	≤5	≤5	≤5
		L2	12~100	≤8	≤8	≤8	≤8	≤8	≤8	≤8	≤8	≤8	≤8	
精密背隙 B2 (arc-min)	L1	3~10	≤3	≤3	≤3	≤3	≤3	≤3	≤3	≤3	≤3	≤3		
L2	12~100	≤4	≤4	≤4	≤4	≤4	≤4	≤4	≤4	≤4	≤4			
精密背隙 B1 (arc-min)	L1	3~10	≤2	≤2	≤2	≤2	≤2	≤2	≤2	≤2	≤2	≤2		
L2	12~100	≤3	≤3	≤3	≤3	≤3	≤3	≤3	≤3	≤3	≤3			
精密背隙 B0 (arc-min)	L1	3~10	≤1	≤1	≤1	≤1	≤1	≤1	≤1	≤1	≤1	≤1		
L1	3~10	≤2	≤2	≤2	≤2	≤2	≤2	≤2	≤2	≤2	≤2			
容許徑向力 (N)	L1, L2	3~100	2800	3900	5500	9800	9800	16500	16500	24100	24100	32600		
容許軸向力 (N)	L1, L2	3~100	2800	3900	5500	9800	9800	16500	16500	24100	24100	32600		
效率 (%)	L1	3~10	90%											
L2	12~100	85%												
重量 (kg)	L1	3~10	2.5	4.3	7.8	20.8	15.5	35.5	28.5	55	40.5	300		
L2	12~100	3.8	6.3	9.2	24.3	18.2	40.5	31.2	65.5	48.5	330			
使用溫度 (°C)	L1, L2	3~100	-10°C~+80°C											
潤滑油	L1, L2	3~100	全合成潤滑油 (COMPLEX HV2) Fully Synthetic Grease											
安裝方向	L1, L2	3~100	任意方向 Any Installation Direction											
噪音值 (db)	L1, L2	3~100	≤65	≤68	≤68	≤68	≤68	≤70	≤70	≤72	≤72	≤72		

*1/2, 入力轉速需 ≤2000 RPM以內.

*1/3, 入力轉速需 ≤3000 RPM以內.

*入力軸與法蘭詳細尺寸C1~C7, 如頁數 57P

型號說明 Model Description



AAW系列: AAW070AS~AAW320AS(BS)

AAW080AS — L1 — 20 — RF — S1 — B1 — Y

段數 Stages
L1(一段比數)
L2(二段比數)

伺服馬達記號: S1~S11
*無記號需提供:
伺服電機廠牌/規格

無記號:
代表標準型
特殊記號:
輸入端與輸出
端尺寸依客戶
指定製作。

AAW070AS
AAW080AS
AAW110AS
AAW135AS(BS)
AAW165AS(BS)
AAW200AS(BS)
AAW320AS(BS)

輸出軸型式: Output shaft type
P: 單實心出力軸
2P: 雙實心出力軸
CR: 中空軸帶鍵槽
RF: 中空軸旋轉法蘭
RF-K: 中空軸旋轉法蘭+鍵槽
RFHP: 中空軸+錐形迫緊環
HR: 中空旋轉平台
BS: 滾珠螺桿型

背隙等級 (AAW070AS~320AS)
無記號: 代表標準背隙
L1 ≤ 5 弧分 L2 ≤ 8 弧分
精密背隙 B1
L1 ≤ 2 弧分 L2 ≤ 3 弧分
精密背隙 B2
L1 ≤ 3 弧分 L2 ≤ 4 弧分
*特殊型: B0 超精密背隙
(L1 ≤ 1 弧分 L2 ≤ 2 弧分)

減速機比數 Ratio of Reducer: AAW070AS~AAW320AS(BS)
L1(一段比數): 2, 3, 5, 6, 8, 9, 10, 12, 15, 16, 18, 20, 21, 24, 30
L2(二段比數): 24, 32, 36, 40, 42, 45, 48, 50, 56, 60, 63, 70, 75, 80, 84, 90, 100, 105, 120, 140, 150, 160, 180, 200, 210, 240, 300
P. S: AAW070AS(1/3, 1/5, 1/10, 1/15, 1/20, 1/25, 1/30, 1/40, 1/50, 1/70, 1/100)

型號說明 Model Description

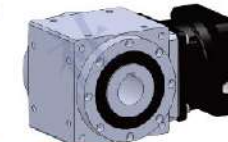

AAT系列: AAT(M)070AS~AAT(M)320AS

AAT080AS — 2 — P — L — S

減速比: Reduction Ratio
2, 3, 5, 7, 10
*開發中減速比: 5, 7, 10

輸出軸型式: Output shaft type
P: 單出力軸 2P: 雙出力軸 CR: 中空軸有鍵
RF: 中空旋轉法蘭
RFHP: 中空軸迫緊環
*特殊型 RFC: 中軸軸夾緊式帶鍵槽

入力尺寸記號:
S1~S11: 入力尺寸記號
註:
1. 無記號需註記伺服
電機廠牌規格
2. RT 無此記號

輸入軸與輸出軸方向:
無記號: CR
L: 左旋轉(入力右轉-出力左轉)
R: 右旋轉(入力右轉-出力右轉)

減速機型號: Reducer Model
AAT080AS, AAT110AS, AAT135AS, AAT165AS, AAT200BS
AATM070AS, AATM080AS, AATM110AS, AATM135AS, AATM165AS, AATM200BS, AATM320AS
AATM080AS-2AX, AATM110AS-2AX, AATM135AS-2AX, AATM165AS-2AX, AATM200BS-2AX

AAW-A(B)S系列-RF 大中空軸旋轉法蘭型式

Big Hollow Shaft Rotary Flange Type

*AAW070AS~~AAW320AS:減速比Ratio(1/2~~1/500)



外形尺寸圖 Dimensions:

Unit:mm

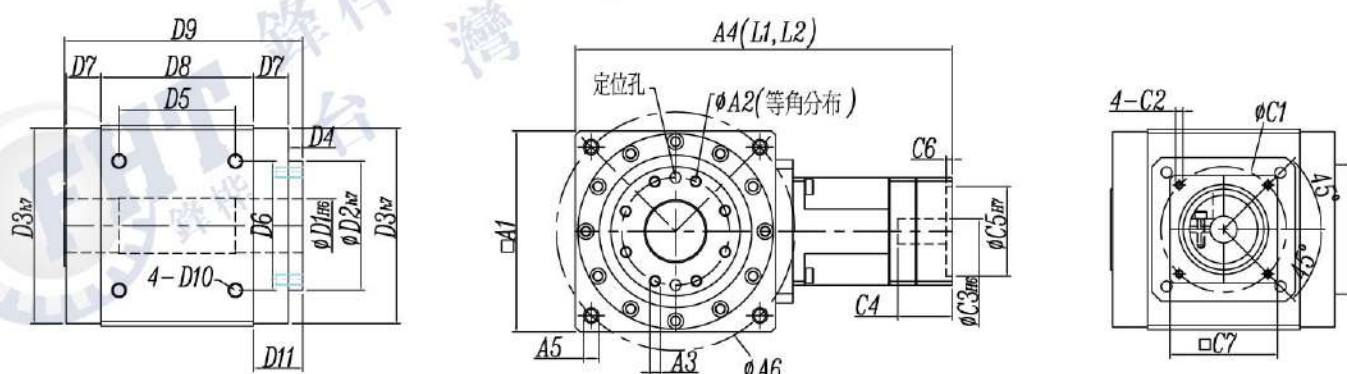

P.S:A6(可選擇通孔)

規格表 Specifications:

Unit:mm

規格	AAW070AS	AAW080AS	AAW110AS	AAW135AS	AAW135BS	AAW165AS	AAW165BS	AAW200AS	AAW200BS	AAW320AS	AAW320BS
A1	70	80	110	138	135	168	165	200	200	320	320
A2	30	36	50	70	70	95	95	124	124	193	193
A3	6-M5-10L	8-M5-10L	8-M5-15L	8-M8-15L	8-M8-15L	8-M8-15L	8-M8-15L	12-M8-15L	12-M8-15L	12-M14-25L	12-M14-18L
A4 (L1單段)	160/168	175/167	226/224	303/290	252/250	359/343	334/321	397/413	423/407	671	539
A4 (L2雙段)	183/199	206/190	268/255	362/331	290/277	434/389	393/356	487/464	469/424	741	590
A5	4-M5-10L	4-M6-12L	4-M8-15L	4-M10-18L	4-M10-18L	4-M12-20L	4-M12-20L	4-M16-30L	4-M16-30L	4-M20-35L	4-M20-30L
A6	75	93	130	160	160	193	193	240	240	380	380
D1	16	20	30	40	40	55	55	80	80	110	110
D2	38	45	65	85	85	110	110	140	140	220	220
D3	60	78	106	133	133	163	163	195	195	306	306
D4	8.25	7	9.5	9.5	9.5	17	17	22	22	17.5	17.5
D5	42.43	49.5	68	86	78	106	100	141	129	170	170
D6	42.43	49.5	65	83	83	105	105	130	130	220	220
D7	6.25	13	15	10	19	13	19	8.5	22	30	30
D8	70	67	90	120	102	142	130	182	155	236	236
D9	92.25	102	131.5	151.5	151.5	187	187	223	223	316.5	316.5
D10	4-M5-10L	4-M6-12L	4-M8-15L	4-M10-18L	4-M10-18L	4-M14-16L	4-M14-16L	4-M14-20L	4-M14-20L	6-M20-35L	6-M20-35L
D11	14.5	20	24.5	19.5	28.5	30	36	30.5	44	47.5	47.5
C1	≤70	≤90	≤145	≤200	≤145	≤215	≤200	≤215	≤215	≤400	≤265
C2	≤M5	≤M6	≤M8	≤M12	≤M8	≤M12	≤M12	≤M12	≤M12	≤M18	≤M14
C3	≤14	≤19	≤24	≤35	≤24	≤42	≤35	≤42	≤42	≤60	≤55
C4	≤31	≤41	≤62	≤80	≤62	≤116	≤80	≤116	≤116	≤145	≤116
C5	≤50	≤70	≤110	≤114.3	≤110	≤180	≤114.3	≤180	≤180	≤300	≤230
C6	≤3.5	≤3.5	≤7	≤7	≤7	≤7	≤7	≤7	≤7	≤7	≤7
C7	≤62	≤80	≤120	≤180	≤120	≤200	≤180	≤200	≤200	≤350	≤250

*入力軸與法蘭詳細尺寸C1~C7,如頁數57P

AAW-A(B)S系列-RFHP 大中空軸迫緊環型式

Big Hollow Shaft Tight Ring Type

*AAW070AS~~AAW320A(B)S:減速比Ratio(1/2~~1/500)



外形尺寸圖 Dimensions:

Unit:mm

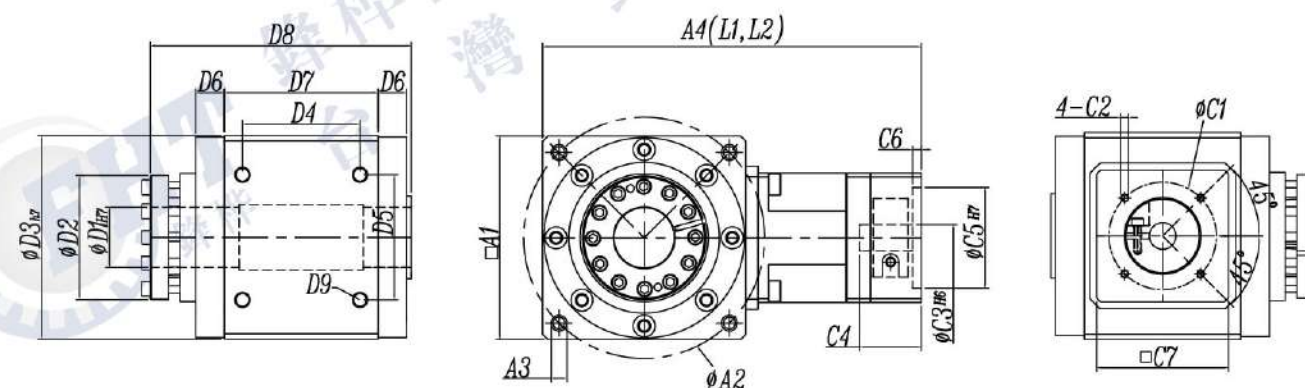

P.S:A2(可選擇通孔)

規格表 Specifications:

Unit:mm

規格	AAW080AS	AAW110AS	AAW135AS	AAW135BS	AAW165AS	AAW165BS	AAW200AS	AAW200BS	AAW320AS	AAW320BS
A1	80	110	138	135	168	165	200	200	320	320
A2	93	130	160	160	193	193	240	240	380	380
A3	4-M6-12L	4-M8-15L	4-M10-18L	4-M10-18L	4-M12-20L	4-M12-20L	4-M16-30L	4-M16-30L	4-M20-35L	4-M20-35L
A4 (L1單段)	175/167	226/224	303/290	252/250	359/343	334/321	397/413	423/407	671	539
A4 (L2雙段)	206/190	268/255	362/331	290/277	434/389	393/356	487/464	469/424	741	590
D1	20	30	40	40	55	55	65	65	105	105
D2	45	65	85	85	110	110	140	140	220	220
D3	78	106	133	133	163	163	195	195	306	306
D4	49.5	68	86	78	106	100	141	129	175	175
D5	49.5	65	83	83	105	105	130	130	220	220
D6	13	15	10	19	13	19	8.5	22	30	30
D7	67	90	120	102	142	130	182	155	236	236
D8	113	144.5	173.5	173.5	206	206	243.5	243.5	337	337
D9	4-M6-12L	4-M8-15L	4-M10-18L	4-M10-18L	4-M14-16L	4-M14-16L	4-M14-20L	4-M14-20L	6-M20-30L	6-M20-30L
C1	≤90	≤145	≤200	≤145	≤215	≤200	≤215	≤215	≤400	≤265
C2	≤M6	≤M8	≤M12	≤M8	≤M12	≤M12	≤M12	≤M12	≤M18	≤M14
C3	≤19	≤24	≤35	≤24	≤42	≤35	≤42	≤42	≤60	≤55
C4	≤41	≤62	≤80	≤62	≤116	≤80	≤116	≤116	≤145	≤116
C5	≤70	≤110	≤114.3	≤110	≤180	≤114.3	≤180	≤180	≤300	≤230
C6	≤3.5	≤7	≤7	≤7	≤7	≤7	≤7	≤7	≤7	≤7
C7	≤80	≤120	≤180	≤120	≤200	≤180	≤200	≤200	≤350	≤250

*入力軸與法蘭詳細尺寸C1~C7,如頁數57P

AAW-A(B)S系列- RFK 法蘭帶鍵型式

Flange With Key Groove Type

*AAW070AS~~AAW200A(B)S:減速比Ratio(1/2~~1/500)

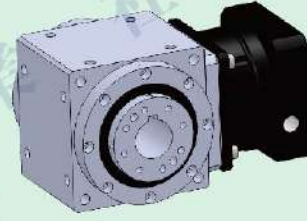

外形尺寸圖 Dimensions:

Unit:mm

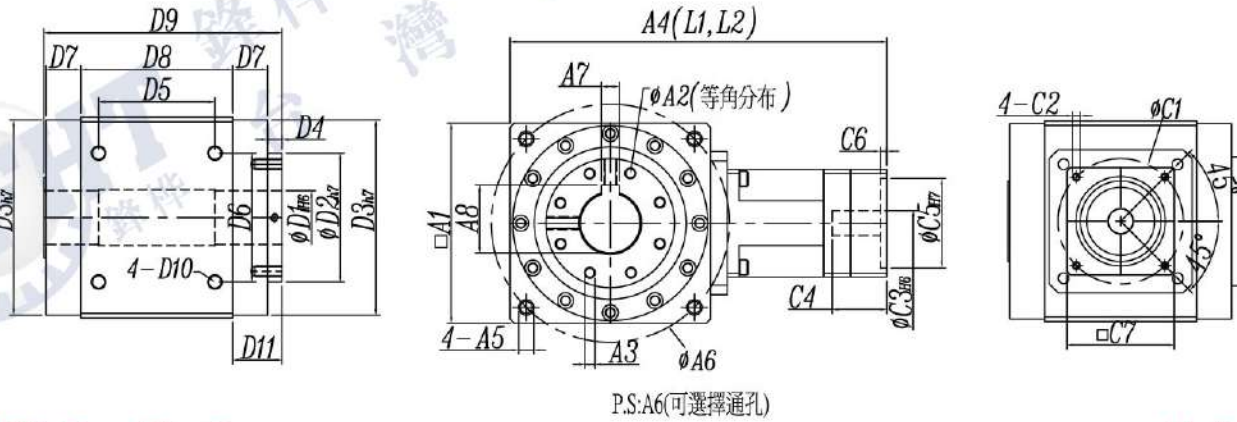

規格表 Specifications:

Unit:mm

規格	AAW070AS	AAW080AS	AAW110AS	AAW135AS	AAW135BS	AAW165AS	AAW165BS	AAW200AS	AAW200BS
A1	70	80	110	138	135	168	165	200	200
A2	30	36	50	70	70	95	95	124	124
A3	6-M5-10L	8-M5-10L	8-M5-15L	8-M8-15L	8-M8-15L	8-M8-15L	8-M8-15L	12-M8-15L	12-M8-15L
A4 (L1單段)	160/168	175/167	226/224	303/290	252/250	359/343	334/321	397/413	423/407
A4 (L2雙段)	183/199	206/190	264/250	362/331	290/277	434/389	393/356	487/464	469/424
A5	4-M5-10L	4-M6-12L	4-M8-15L	4-M10-18L	4-M10-18L	4-M12-20L	4-M12-20L	4-M14-25L	4-M14-25L
A6	75	93	130	160	160	193	193	240	240
A7	5	6	8	12	12	14	14	18	18
A8	18	22.8	33.3	43.3	43.3	59.1	59.1	84.7	84.7
D1	16	20	30	40	40	55	55	80	80
D2	38	45	65	85	85	110	110	140	140
D3	60	78	106	133	133	163	163	195	195
D4	8.25	7	9.5	9.5	9.5	17	17	22	22
D5	42.43	49.5	68	86	78	106	100	141	129
D6	42.43	49.5	65	83	83	105	105	130	130
D7	6.25	13	15	10	19	13	19	8.5	22
D8	70	67	90	120	102	142	130	182	155
D9	92.25	102	131.5	151.5	151.5	187	187	223	223
D10	4-M5-10L	M6-12L	M8-15L	M10-18L	M10-18L	M14-16L	M14-16L	M14-20L	M14-20L
D11	14.5	20	24.5	19.5	28.5	30	36	30.5	44
C1	≤70	≤90	≤145	≤200	≤145	≤215	≤200	≤215	≤215
C2	≤M5	≤M6	≤M8	≤M12	≤M8	≤M12	≤M12	≤M12	≤M12
C3	≤14	≤19	≤24	≤35	≤24	≤42	≤35	≤42	≤42
C4	≤31	≤41	≤62	≤80	≤62	≤116	≤80	≤116	≤116
C5	≤50	≤70	≤110	≤114.3	≤110	≤180	≤114.3	≤180	≤180
C6	≤3.5	≤3.5	≤7	≤7	≤7	≤7	≤7	≤7	≤7
C7	≤62	≤80	≤120	≤180	≤120	≤200	≤180	≤200	≤200

*入力軸與法蘭詳細尺寸C1~C7,如頁數57P

AAW-A(B)S系列-2P 雙出力軸型式

Double Output Shaft Type

*AAW080AS~~AAW200A(B)S:減速比Ratio(1/2~~1/500)



外形尺寸圖 Dimensions:

Unit:mm

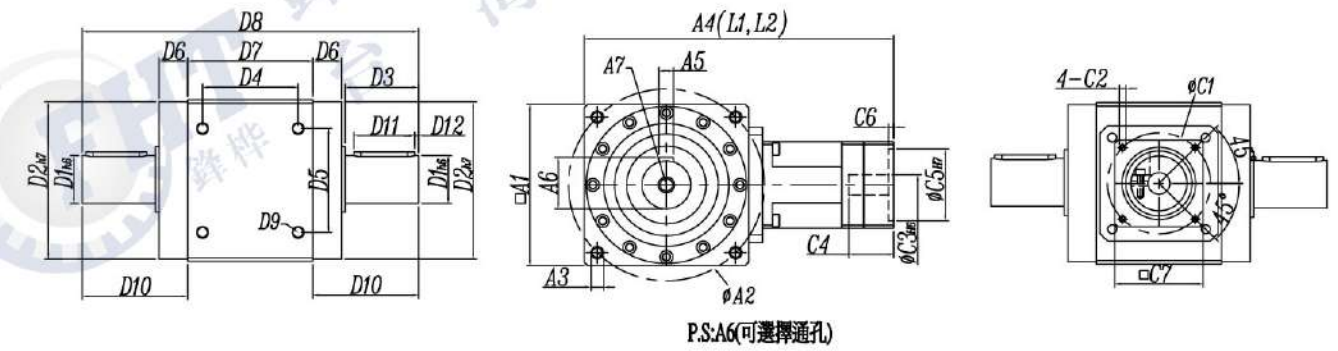

規格表 Specifications:

Unit:mm

規格	AAW080AS	AAW110AS	AAW135AS	AAW135BS	AAW165AS	AAW165BS	AAW200AS	AAW200BS
A1	80	110	138	135	168	165	200	200
A2	93	130	160	160	193	193	240	240
A3	4-M6-12L	4-M8-15L	4-M10-18L	4-M10-18L	4-M12-20L	4-M12-20L	4-M16-30L	4-M16-30L
A4 (L1單段)	175/167	226/224	303/290	252/250	359/343	334/321	397/413	423/407
A4 (L2雙段)	206/190	268/255	362/331	290/277	434/389	393/356	487/464	469/424
A5	6	8	12	12	16	16	20	20
A6	22.5	33	43	43	59	59	79.5	79.5
A7	M6	M8	M12	M12	M16	M16	M20	M20
D1	20	30	40	40	55	55	75	75
D2	78	106	133	133	163	163	195	195
D3	35	45	55	55	80	80	100	100
D4	49.5	68	86	78	106	100	141	129
D5	49.5	65	83	83	105	105	130	130
D6	13	15	10	19	13	19	8.5	22
D7	67	90	120	102	142	130	182	155
D8	166.5	214	256	256	332	332	402	402
D9	M6-12L	M8-15L	M10-18L	M10-18L	M14-16L	M14-16L	M14-20L	M14-20L
D10	49.75	62	68	68	95	95	110	110
D11	25	35	45	45	70	70	90	90
D12	5	5	5	5	3	3	5	5
C1	≤90	≤145	≤200	≤145	≤215	≤200	≤215	≤215
C2	≤M6	≤M8	≤M12	≤M8	≤M12	≤M12	≤M12	≤M12
C3	≤19	≤24	≤35	≤24	≤42	≤35	≤42	≤42
C4	≤41	≤62	≤80	≤62	≤116	≤80	≤116	≤116
C5	≤70	≤110	≤114.3	≤110	≤180	≤114.3	≤180	≤180
C6	≤3.5	≤7	≤7	≤7	≤7	≤7	≤7	≤7
C7	≤80	≤120	≤180	≤120	≤200	≤180	≤200	≤200

*入力軸與法蘭詳細尺寸C1~C7,如頁數57P

AAW-A(B)S系列-P系列 單出力軸型式

Single Output Shaft Type

*AAW080AS~~AAW200A(B)S:減速比Ratio(1/2~~1/500)



外形尺寸圖 Dimensions:

Unit:mm

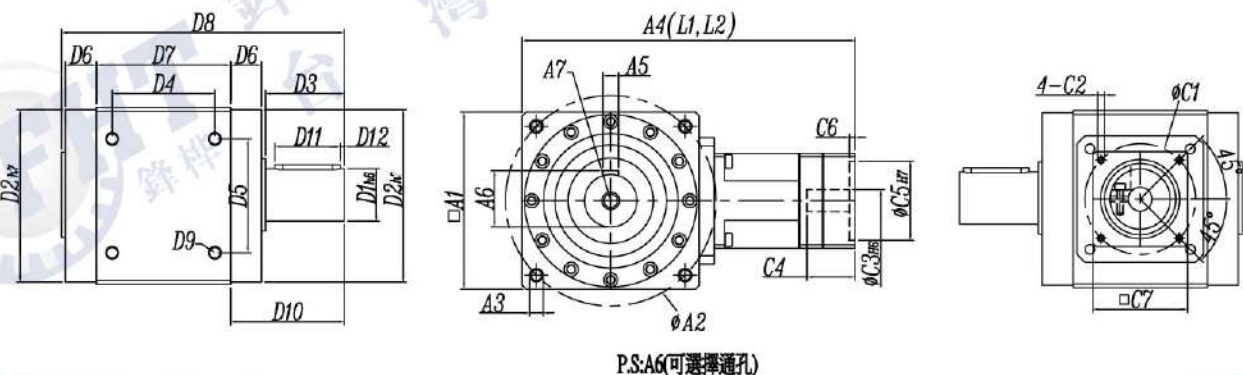

P.S:A6(可選擇通孔)

規格表 Specifications:

Unit:mm

規格	AAW080AS	AAW110AS	AAW135AS	AAW135BS	AAW165AS	AAW165BS	AAW200AS	AAW200BS	AAW320AS	AAW320BS
A1	80	110	138	135	168	165	200	200	320	320
A2	93	130	160	160	193	193	240	240	380	380
A3	4-M6-12L	4-M8-15L	4-M10-18L	4-M10-18L	4-M12-20L	4-M12-20L	4-M16-30L	4-M16-30L	4-M20-35L	4-M20-35L
A4 (L1型)	175/167	226/224	303/290	252/250	359/343	334/321	397/413	423/407	671	539
A4 (L2型)	206/190	268/255	362/331	290/277	434/389	393/356	487/464	469/424	741	590
A5	6	8	12	12	16	16	20	20	32	32
A6	22.5	33	43	43	59	59	79.5	79.5	127	127
A7	M6	M8	M12	M12	M16	M16	M20	M20	M20	M20
D1	20	30	40	40	55	55	75	75	120	120
D2	78	106	133	133	163	163	195	195	306	306
D3	35	45	55	55	80	80	100	100	150	150
D4	49.5	68	86	78	106	100	141	129	170	170
D5	49.5	65	83	83	105	105	130	130	220	220
D6	13	15	10	19	13	19	8.5	22	30	30
D7	67	90	120	102	142	130	182	155	236	236
D8	131.5	169	201	201	252	252	302	302	452	452
D9	M6-12L	M8-15L	M10-18L	M10-18L	M14-16L	M14-16L	M14-20L	M14-20L	6-M20-30L	6-M20-30L
D10	49.75	62	68	68	95	95	110	110	183	183
D11	25	35	45	45	70	70	90	90	120	120
D12	5	5	5	5	3	3	5	5	15	15
C1	≤90	≤145	≤200	≤145	≤215	≤200	≤215	≤215	≤350	≤215
C2	≤M6	≤M8	≤M12	≤M8	≤M12	≤M12	≤M12	≤M12	≤M18	≤M12
C3	≤19	≤24	≤35	≤24	≤42	≤35	≤42	≤42	≤60	≤42
C4	≤41	≤62	≤80	≤62	≤116	≤80	≤116	≤116	≤135	≤116
C5	≤70	≤110	≤114.3	≤110	≤180	≤114.3	≤180	≤180	≤250	≤180
C6	≤3.5	≤7	≤7	≤7	≤7	≤7	≤7	≤7	≤7	≤7
C7	≤80	≤120	≤180	≤120	≤200	≤180	≤200	≤200	≤300	≤200

*入力軸與法蘭詳細尺寸C1~C7,如頁數57P

螺桿減速機 Screw Reducer

AAW080AS~~200AS-L1(2)-□-BS-S□

*BS :螺桿代號 Screw Code

*L1(2)-□:齒輪比 Gear Ratio

*S□:S1~S11(入力端尺寸記號) Input End Size Mark



外形尺寸圖 Dimensions:

Unit:mm

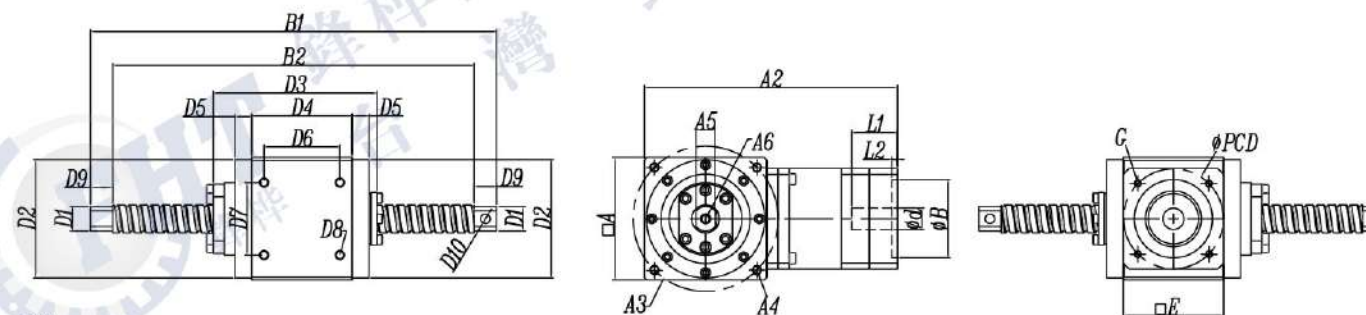

P.S:

1. 螺桿長度 B1(B2) 依客戶指定製作
2. 二 軸端之尺寸依客戶指定而製作
3. A4尺寸(可選擇通孔)

規格表 Specifications:

Unit:mm

規格	AAW080AS-BS	AAW110AS-BS	AAW135AS-BS	AAW135BS-BS	AAW165AS-BS	AAW165BS-BS	AAW200AS-BS	AAW200BS-BS
□A1	80	110	138	138	168	168	200	200
A2	157.7	192.5	244.5	244.5	278	278	312	312
A3	93	130	160	160	193	193	240	240
A4	4-M6-12L	4-M8-15L	4-M10-18L	4-M10-18L	4-M12-20L	4-M12-20L	4-M16-30L	4-M16-30L
A5	12	17	22	22	33	33	43	43
A6	M6	M8	M10	M10	M12	M12	M16	M16
φD1 _{H7}	16	25	32	32	40	40	50	50
φD2 _{H7}	78	106	133	133	163	163	195	195
D3 (±3mm)	125	158	184	184	223	223	263	263
D4	67	90	120	120	142	142	182	155
D5	13	15	10	10	13	13	8.5	22
D6	49.5	68	86	86	106	106	141	129
D7	49.5	65	83	83	105	105	130	130
D8	4-M6-12L	4-M8-15L	4-M10-18L	4-M10-18L	4-M14-16L	4-M14-16L	4-M14-25L	4-M14-25L
D9	15	20	25	25	35	35	50	50
D10	6.5	8.5	10.5	10.5	14.5	14.5	20.5	20.5
φd _{H6}	≤19	≤24	≤35	≤35	≤42	≤42	≤42	≤42
φB _{H7}	≤70	≤110	≤114.3	≤114.3	≤180	≤180	≤180	≤180
L1	≤41	≤60	≤80	≤80	≤116	≤116	≤116	≤116
L2	≤5	≤6	≤6	≤6	≤6	≤6	≤6	≤6
PCD	≤90	≤145	≤200	≤200	≤235	≤235	≤235	≤235
G	≤4-M6	≤4-M8	≤4-M12	≤4-M12	≤4-M12	≤4-M12	≤4-M12	≤4-M12
□E	≤80	≤120	≤176	≤176	≤200	≤200	≤200	≤200

*入力軸與法蘭詳細尺寸C1~C7,如頁數57P

AATM系列-RF大中空軸旋轉法蘭型式

Big Hollow Shaft Rotary Flange Type

*AATM070AS~~AATM320AS:減速比Ratio(1/2~1/10)

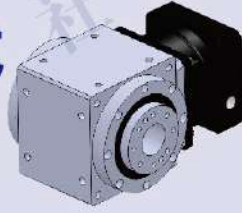

外形尺寸圖 Dimensions:

Unit:mm

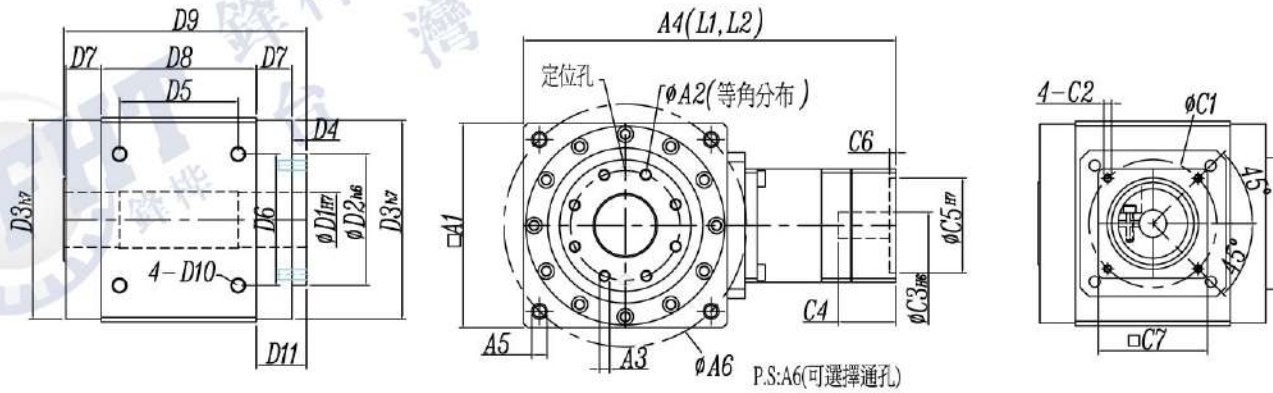

規格表 Specifications:

Unit:mm

規格	AATM070AS	AATM080AS	AATM110AS	AATM135AS	AATM165AS	AATM200BS	AATM320AS
A1	70	80	110	138	168	200	320
A2	30	36	50	70	95	124	193
A3	6-M5-10L	8-M5-10L	8-M5-15L	8-M8-15L	8-M8-15L	12-M8-15L	12-M14-25L
A4	146.5	157.7	192.5	244.5	278	312	491.5
A5	4-M5-10L	4-M6-12L	4-M8-15L	4-M10-18L	4-M12-20L	4-M16-30L	4-M20-35L
A6	75	93	130	160	193	240	380
D1	16	20	30	40	55	80	110
D2	38	45	65	85	110	140	220
D3	60	78	106	133	163	195	306
D4	8.25	7	9.5	9.5	17	22	17.5
D5	42.43	49.5	68	86	106	129	170
D6	42.43	49.5	65	83	105	130	220
D7	6.25	13	15	10	13	22	30
D8	70	67	90	120	142	155	236
D9	92.25	102	131.5	151.5	187	223	316.5
D10	4-M5-10L	4-M6-12L	4-M8-15L	4-M10-18L	4-M14-16L	4-M14-20L	6-M20-30L
D11	14.5	20	24.5	19.5	30	44	47.5
C1	≤70	≤90	≤145	≤200	≤215	≤215	≤450
C2	≤M5	≤M6	≤M8	≤M12	≤M12	≤M12	≤M18
C3	≤14	≤19	≤24	≤35	≤42	≤42	≤65
C4	≤31	≤41	≤62	≤80	≤116	≤116	≤135
C5	≤50	≤70	≤110	≤114.3	≤180	≤180	≤350
C6	≤3.5	≤3.5	≤7	≤7	≤7	≤7	≤7
C7	≤62	≤80	≤120	≤180	≤200	≤200	≤400

*入力軸與法蘭詳細尺寸C1~C7,如頁數57P

AATM系列-RFHP中空軸迫緊環形式

Hollow Shaft Tight Ring Type

*AATM080AS~AATM320AS,減速比Ratio(1/2~1/10)



外形尺寸圖 Dimensions:

Unit:mm

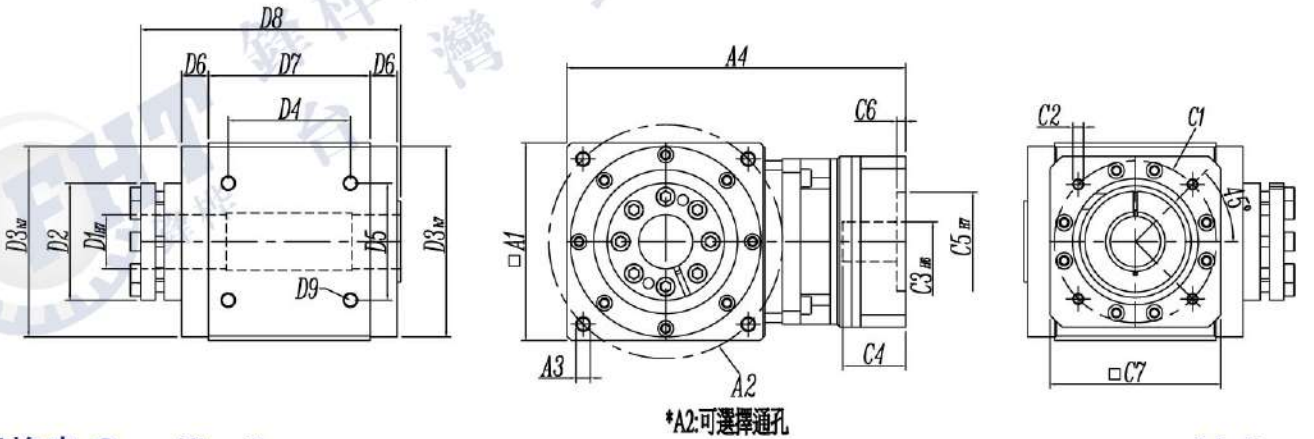

規格表 Specifications:

Unit:mm

規格	AATM080AS	AATM110AS	AATM135AS	AATM165AS	AATM200BS	AATM320AS
A1	80	110	138	168	200	320
A2	93	130	160	193	240	380
A3	4-M6-12L	4-M8-12L	4-M10-15L	4-M12-18L	4-M16-30L	4-M20-35L
A4	157.7	192.5	244.5	278	312	491.5
D1	20	30	40	55	65	105
D2	45	65	85	110	140	170
D3	78	106	133	163	195	306
D4	49.5	68	86	106	129	170
D5	49.5	65	83	105	130	220
D6	13	15	10	13	22	30
D7	67	90	120	142	155	236
D8	113	144.5	173.5	206	243.5	302
D9	4-M6-12L	4-M8-15L	4-M10-18L	4-M14-16L	4-M14-25L	4-M20-30L
C1	≤90	≤145	≤145	≤200	≤215	≤450
C2	≤M6	≤M8	≤M8	≤M12	≤M12	≤M18
C3	≤19	≤24	≤24	≤35	≤42	≤65
C4	≤41	≤62	≤62	≤80	≤116	≤135
C5	≤70	≤110	≤110	≤114.3	≤180	≤350
C6	≤5	≤7	≤7	≤7	≤7	≤7
C7	≤80	≤120	≤120	≤176	≤196	≤400

*入力軸與法蘭詳細尺寸C1~C7,如頁數57P

AATM系列-CR中空軸帶鍵槽型式

Hollow Shaft Key Groove Type

*AATM080AS~AATM200BS,減速比Ratio(1/2~1/10)

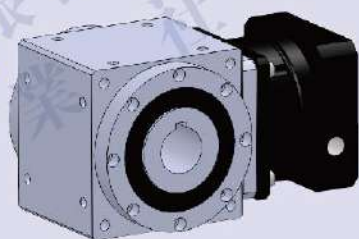

外形尺寸圖 Dimensions:

Unit:mm

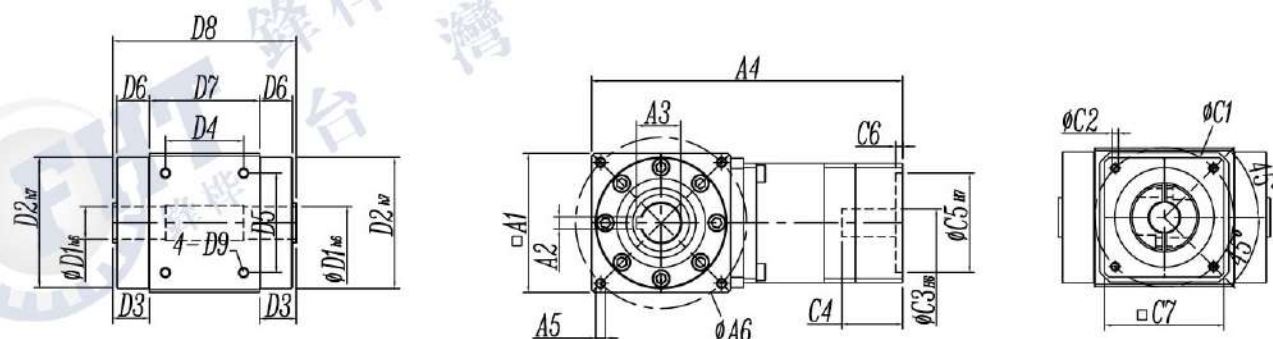

*A6:可選擇通孔

規格表 Specifications:

Unit:mm

規格	AATM080AS	AATM110AS	AATM135AS	AATM165AS	AATM200BS
A1	80	110	138	168	200
A2	6	8	12	14	18
A3	22.7	33.3	43.3	58.8	84.4
A4	157.7	192.5	244.5	278	312
A5	4-M6-12L	4-M8-12L	4-M10-15L	4-M12-18L	4-M16-30L
A6	93	130	160	193	240
D1	20	30	40	55	75
D2	78	106	133	163	195
D3	14.25	17	13	15	23.5
D4	49.5	68	86	106	129
D5	49.5	65	83	105	130
D6	13	15	10	13	22
D7	67	90	120	142	155
D8	96.5	124	146	170	202
D9	4-M6-12L	4-M8-15L	4-M10-18L	4-M14-16L	4-M14-25L
C1	≤90	≤145	≤145	≤200	≤215
C2	≤M6	≤M8	≤M8	≤M12	≤M12
C3	≤19	≤24	≤24	≤35	≤42
C4	≤41	≤62	≤62	≤80	≤116
C5	≤70	≤110	≤110	≤114.3	≤180
C6	≤5	≤7	≤7	≤7	≤7
C7	≤80	≤120	≤120	≤176	≤196

*入力軸與法蘭詳細尺寸C1~C7,如頁數57P

AATM系列-2P雙出力軸型式

Double Output Shaft Type

*AATM080AS~AATM200BS,減速比Ratio(1/2~1/10)

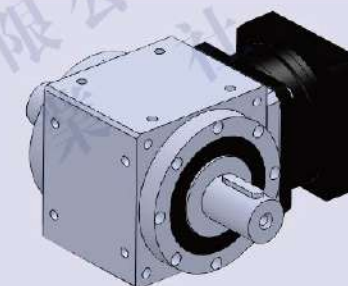

外形尺寸圖 Dimensions:

Unit:mm

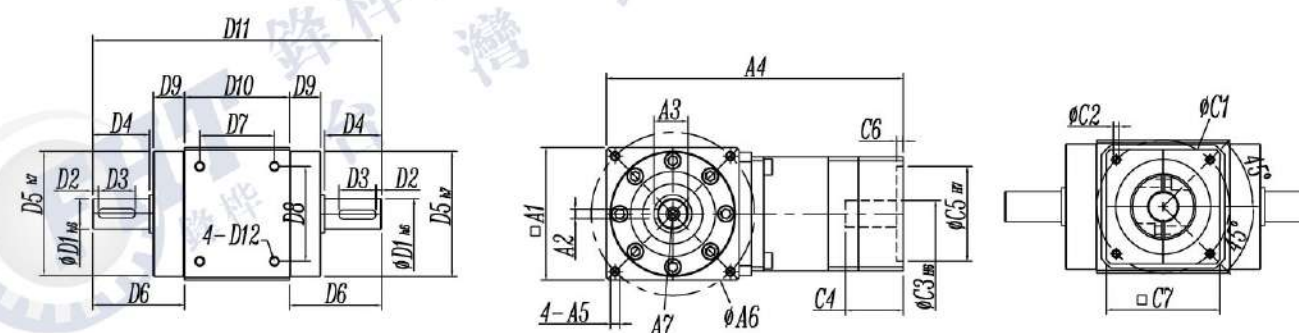

*A6:可選擇通孔

規格表 Specifications:

Unit:mm

規格	AATM080AS	AATM110AS	AATM135AS	AATM165AS	AATM200BS
A1	80	110	138	168	200
A2	6	8	12	16	20
A3	22.5	33	43	59	79.5
A4	157.7	192.5	244.5	278	312
A5	4-M6-12L	4-M8-12L	4-M10-15L	4-M12-18L	4-M16-30L
A6	93	130	160	193	240
A7	M6	M8	M12	M16	M20
D1	20	30	40	55	75
D2	5	5	5	3	5
D3	25	35	45	70	90
D4	35	45	55	80	100
D5	78	106	133	163	195
D6	49.75	62	68	95	123.5
D7	49.5	68	86	106	129
D8	49.5	65	83	105	130
D9	13	15	10	13	22
D10	67	90	102	130	155
D11	166.5	214	256	332	402
D12	4-M6-12L	4-M8-15L	4-M10-18L	4-M14-16L	4-M14-25L
C1	≤90	≤145	≤145	≤200	≤215
C2	≤M6	≤M8	≤M8	≤M12	≤M12
C3	≤19	≤24	≤24	≤35	≤42
C4	≤41	≤62	≤62	≤80	≤116
C5	≤70	≤110	≤110	≤114.3	≤180
C6	≤5	≤7	≤7	≤7	≤7
C7	≤80	≤120	≤120	≤176	≤196

*入力軸與法蘭詳細尺寸C1~C7,如頁數57P

AATM系列-P單出力軸型式

Single Output Shaft Type

*AATM080~AATM320AS,減速比Ratio(1/2~1/10)

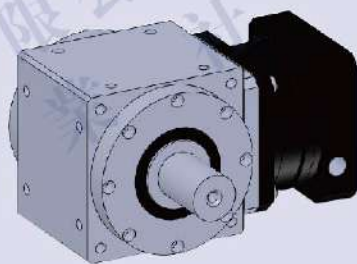

外形尺寸圖 Dimensions:

Unit:mm

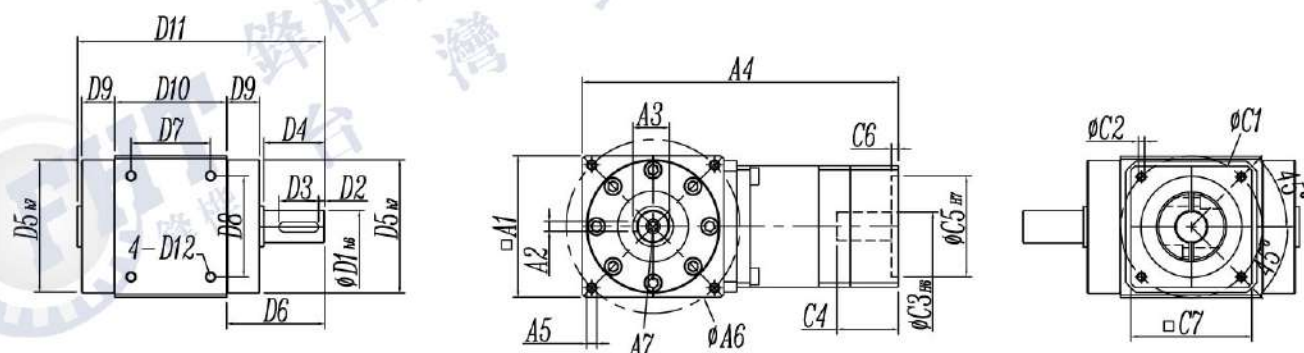

*A6:可選擇通孔

規格表 Specifications:

Unit:mm

規格	AATM080AS	AATM110AS	AATM135AS	AATM165AS	AATM200BS	AATM320AS
A1	80	110	138	168	200	320
A2	6	8	12	16	20	32
A3	22.5	33	43	59	79.5	127
A4	157.7	192.5	244.5	278	312	491.5
A5	4-M6-12L	4-M8-12L	4-M10-15L	4-M12-18L	4-M16-30L	4-M20-35L
A6	93	130	160	193	240	380
A7	M6	M8	M12	M16	M20	M20
D1	20	30	40	55	75	120
D2	5	5	5	3	5	15
D3	25	35	45	70	90	120
D4	35	45	55	80	100	150
D5	78	106	133	163	195	306
D6	49.75	62	68	95	123.5	183
D7	49.5	68	86	106	129	170
D8	49.5	65	83	105	130	220
D9	13	15	10	13	22	30
D10	67	90	120	142	155	155
D11	131.5	169	201	252	302	365
D12	4-M6-12L	4-M8-15L	4-M10-18L	4-M14-16L	4-M14-25L	4-M20-30L
C1	≤90	≤145	≤145	≤200	≤215	≤450
C2	≤M6	≤M8	≤M8	≤M12	≤M12	≤M18
C3	≤19	≤24	≤24	≤35	≤42	≤65
C4	≤41	≤62	≤62	≤80	≤116	≤135
C5	≤70	≤110	≤110	≤114.3	≤180	≤350
C6	≤5	≤7	≤7	≤7	≤7	≤7
C7	≤80	≤120	≤120	≤176	≤196	≤400

*入力軸與法蘭詳細尺寸C1~C7,如頁數57P

AAT系列-CR中空軸帶鍵槽型式

Hollow Shaft Key Groove Type

*轉向器AAT080AS~AAT200BS,速比Ratio(1/2,1/3)

*訂製品速比Ratio of Customized Product(1/5,1/10)

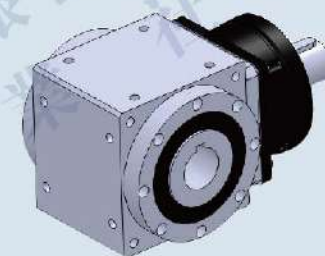

外形尺寸圖 Dimensions:

Unit:mm

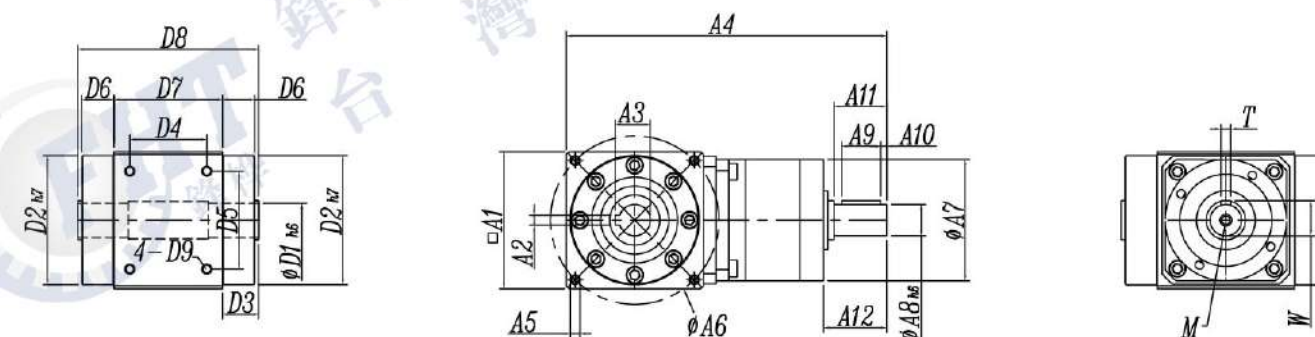

規格表 Specifications:

Unit:mm

規格	AAT080AS	AAT110AS	AAT135AS	AAT165AS	AAT200BS
A1	80	110	138	168	200
A2	6	8	12	14	18
A3	22.7	33.3	43.3	58.8	84.4
A4	173.9	208.5	259.5	317	355
A5	4-M6-12L	4-M8-15L	4-M10-18L	4-M12-20L	4-M16-30L
A6	93	130	160	193	240
A7	62	95	120	142	142
A8	20	28	35	50	50
A9	20	30	40	50	50
A10	3	3	3	3	3
A11	27	34	45	65	65
A12	32.2	41	51.5	70	70
D1	20	30	40	55	75
D2	78	106	133	163	195
D3	14.75	17	13	15	23.5
D4	49.5	68	86	106	141
D5	49.5	65	83	105	130
D6	13	15	10	13	22
D7	67	90	120	142	155
D8	96.5	124	146	172	202
D9	4-M6-12L	4-M8-12L	4-M10-18L	4-M14-16L	4-M14-25L
T	6	8	10	14	14
W	22.5	31	38	53.5	53.5
M	M6	M8	M8	M12	M12

*入力軸與法蘭詳細尺寸C1~C7,如頁數57P

AAT-系列-2P雙出力軸型式

Double Output Shaft Type

*轉向器AAT080AS~AAT200BS,速比Ratio(1/2,1/3)
*訂製品速比Ratio of Customized Product (1/5,1/10)



外形尺寸圖 Dimensions:

Unit:mm

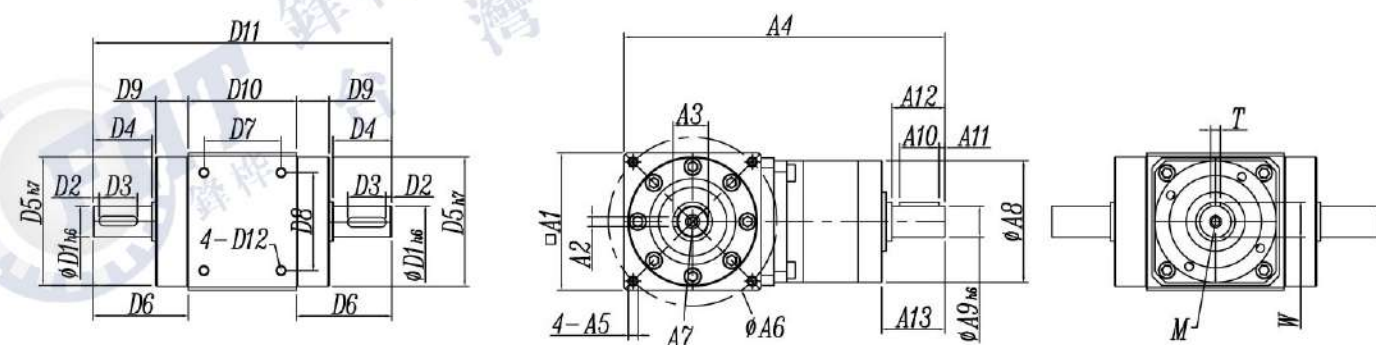

規格表 Specifications:

Unit:mm

規格	AAT080AS	AAT110AS	AAT135AS	AAT165AS	AAT200BS
A1	80	110	138	168	200
A2	6	8	12	16	20
A3	22.5	33	43	59	79.5
A4	173.9	208.5	259.5	317	355
A5	4-M6-12L	4-M8-15L	4-M10-18L	4-M12-20L	4-M16-30L
A6	93	130	160	193	240
A7	M6	M8	M12	M16	M20
A8	62	95	120	142	142
A9	20	28	35	50	50
A10	20	30	40	60	60
A11	3	3	3	3	3
A12	27	40	45	65	65
A13	32.2	44	51.5	70	70
D1	20	30	40	55	75
D2	5	5	5	5	5
D3	25	35	45	70	90
D4	35	45	55	80	100
D5	78	106	133	163	195
D6	49.75	62	68	95	123.5
D7	49.5	68	86	106	141
D8	49.5	65	83	105	130
D9	13	15	10	13	22
D10	67	90	120	142	155
D11	166.5	214	256	332	402
D12	4-M6-12L	4-M8-12L	4-M10-18L	4-M14-16L	4-M14-25L
T	6	8	10	14	14
W	22.5	31	38	53.5	53.5
M	M6	M8	M8	M12	M12

*入力軸與法蘭詳細尺寸C1~C7,如頁數57P

AAT系列-P單出力軸型式

Single Output Shaft Type

*轉向器AAT080AS~AAT200BS,速比Ratio(1/2,1/3)
*訂製品速比Ratio of Customized Product (1/5,1/10)



外形尺寸圖 Dimensions:

Unit:mm

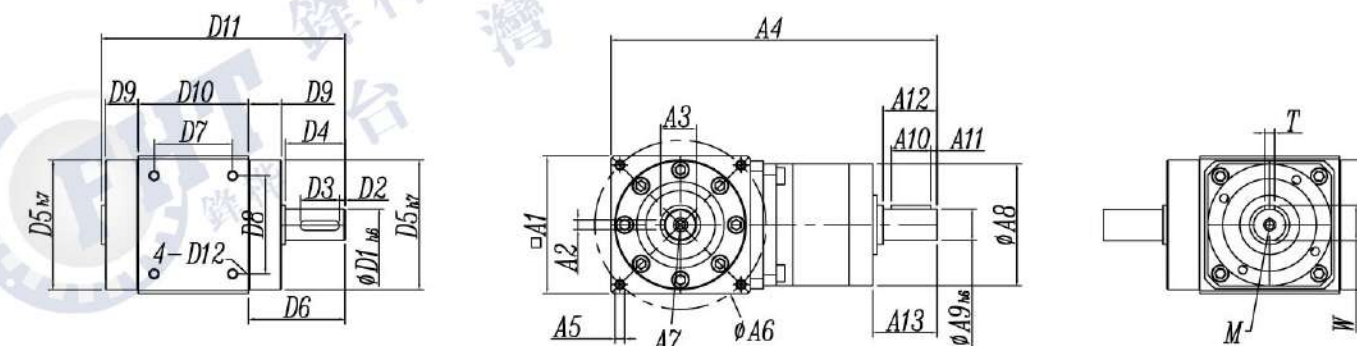

規格表 Specifications:

Unit:mm

規格	AAT080AS [§]	AAT110AS [§]	AAT135AS [§]	AAT165AS [§]	AAT200BS [§]
A1	80	110	135	165	200
A2	6	8	12	16	20
A3	22.5	33	43	59	79.5
A4	173.9	208.5	222	317	355
A5	4-M6-12L	4-M8-15L	4-M10-18L	4-M12-20L	4-M16-30L
A6	93	130	160	193	240
A7	M6	M8	M12	M16	M20
A8	62	95	120	142	142
A9	20	28	35	50	50
A10	20	30	40	60	60
A11	3	3	3	3	3
A12	27	40	45	65	65
A13	32.2	44	51.5	75	70
D1	20	30	40	55	75
D2	5	5	5	5	5
D3	25	35	45	70	90
D4	35	45	55	80	100
D5	78	106	133	163	195
D6	49.75	62	68	95	110
D7	49.5	68	86	106	141
D8	49.5	65	83	105	130
D9	13	15	10	13	22
D10	67	90	120	142	155
D11	131.5	169	201	252	302
D12	4-M6-12L	4-M8-12L	4-M10-18L	4-M14-16L	4-M14-25L
T	6	8	10	14	14
W	22.5	31	38	53.5	53.5
M	M6	M8	M8	M12	M12

*入力軸與法蘭詳細尺寸C1~C7,如頁數57P

AAW-AS(BS) / AAT(M)系列

入力端詳細尺寸圖 Detailed Sizes Diagram of Input End

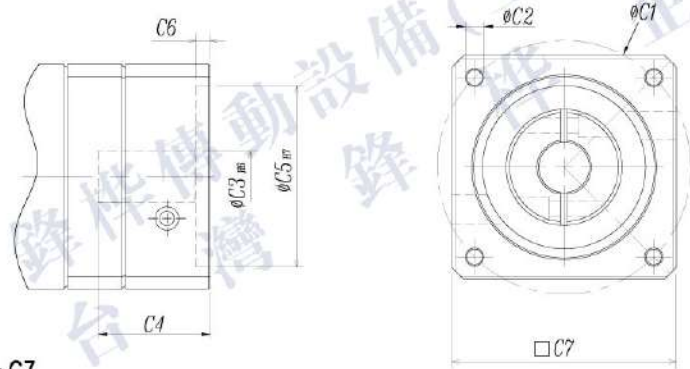

- *入力軸與法蘭詳細尺寸C1~C7.
- *馬達記號是指不同廠牌の入力端尺寸.
- *特製品:可依客戶指定製作入力法蘭尺寸.

型號	AAW070AS/AATM080AS/AAW080AS								AATM110AS/AAW110AS/AAW135BS										
尺寸	S1	S2	S3	S4	S5	S6	S7	S8	S1	S2	S3	S4	S5	S6	S7	S8	S9	S10	S11
C1	45	46	70	70	70	90	90	66.7	70	70	70	90	90	90	90	100	145	145	145
C2	M3	M4	M4	M4	M5	M5	M6	M4	M4	M4	M5	M5	M6	M6	M6	M6	M8	M8	M8
C3 H6	8	8	11	14	14	14	14	6.35	11	14	14	14	14	16	19	16	19	22	24
C4	31	31	31	31	31	31	31	31	41	41	41	41	41	41	41	41	58	58	58
C5 H7	30	30	50	50	50	70	70	38.1	50	50	50	70	70	70	70	80	110	110	110
C6	3.5	3.5	3.5	3.5	3.5	3.5	3.5	3.5	5	5	5	5	5	5	5	5	5	5	5
C7	62	62	62	62	62	80	80	62	90	90	90	90	90	90	90	130	130	130	

型號	AATM135AS/AAW135AS/AAW165BS								AATM165AS/AAW165AS/AATM200BS/AAW200BS									
尺寸	S1	S2	S3	S4	S5	S6	S7	S8	S9	S10	S1	S2	S3	S4	S5	S6	S7	S8
C1	90	90	100	115	115	130	145	145	145	145	115	115	145	145	145	145	200	165
C2	M6	M6	M6	M6	M8	M8	M8	M8	M8	M8	M6	M8	M8	M8	M8	M8	M12	M10
C3 H6	16	19	16	24	24	19	19	22	24	28	24	24	19	22	24	28	35	32
C4	54	54	54	54	54	62	62	62	62	63	60	60	65	65	65	65	81	65
C5 H7	70	70	80	95	95	110	110	110	110	110	95	95	110	110	110	110	114.3	130
C6	7	7	7	7	7	7	7	7	7	7	7	7	7	7	7	7	7	7
C7	120	120	120	120	120	120	120	120	120	120	142	142	142	142	142	142	176	142

型號	AAW200AS/AAW320BS										AAW320AS							
尺寸	S1	S2	S3	S4	S5	S6	S7	S8	S9	S10	S1	S2	S3	S4	S5	S6	S7	
C1	145	145	145	115	200	200	165	215	235	235	265	200	200	215	215	235	235	265
C2	M8	M8	M8	M6	M12	M12	M10	M12	M12	M12	M10	M12	M12	M12	M12	M12	M12	M12
C3 H6	19	22	24	28	35	42	32	38	42	55	55	35	42	38	42	42	55	55
C4	75	75	75	75	81	81	81	116	116	116	116	116	116	116	116	116	116	116
C5 H7	110	110	110	110	114.3	114.3	130	180	200	200	230	114.3	114.3	180	180	200	200	230
C6	10	10	10	10	10	10	10	10	10	10	10	10	10	10	10	10	10	10
C7	180	180	180	180	180	180	180	192	220	220	250	220	220	220	220	200	200	250

*入力軸與法蘭詳細尺寸C1~C7,如頁數57P

減速機與馬達安裝說明書

Installation Instruction of Reducer & Motor

Step 1:
確認馬達減速機規格，並將馬達及減速機之安裝面擦拭乾淨。

Step 2:
取下馬達上原先之鍵。

Step 3:
如有需要請加上軸襯套。

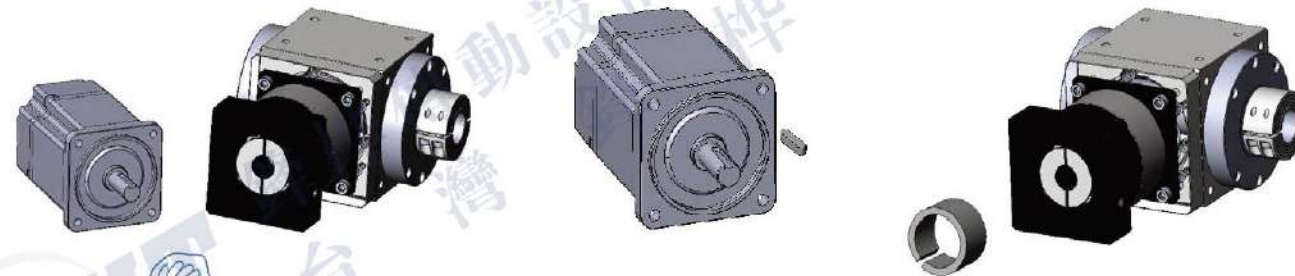

Step 4:
直立式的裝入馬達，以螺絲扭力值表(表一)建議扭力值之5%，依1~4的順序，用扳手將附墊片之螺絲輕輕鎖上。

Step 5:
將馬達與減速機直立擺設，參照表二建議之扭力值，以扭力扳手將埋栓鎖緊。

Step 6:
將馬達與減速機直立擺設，以螺絲扭力表(表一)建議之扭力值，依1~4的順序，用扭力扳手將螺絲鎖緊。

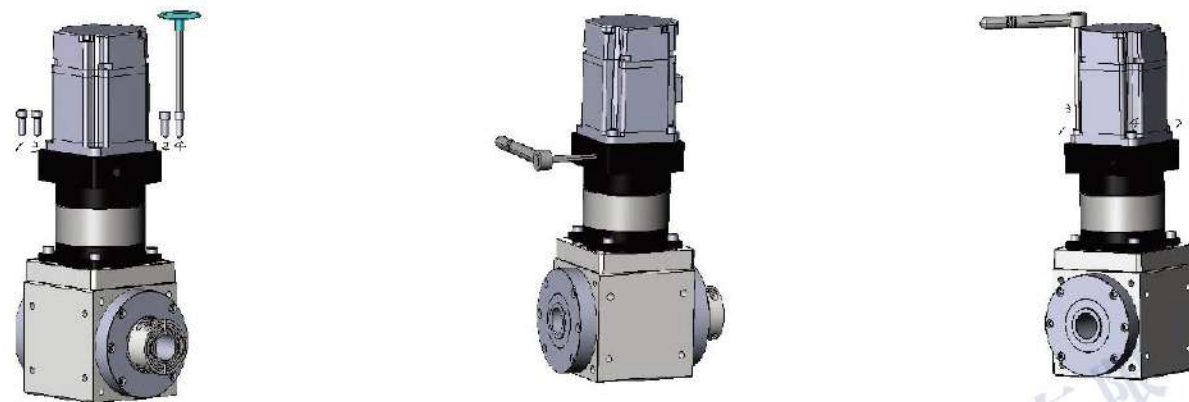

螺絲尺寸	馬達鎖緊螺絲扭力建議表						
	六角頭尺寸 [mm]	強度 8.8 螺絲之鎖緊力		強度 10.9 螺絲之鎖緊力		強度 12.9 螺絲之鎖緊力	
		[Nm]	[In-lbs]	[Nm]	[In-lbs]	[Nm]	[In-lbs]
M3×0.5P	2.5	1.3	12	1.8	16	2.1	19
M4×0.7P	3	3	27	4.1	37	4.9	44
M5×0.8P	4	6.1	55	8.2	73	9.8	87
M6×1P	5	11	98	14	124	17	151
M8×1.25P	6	25	222	34	302	41	364
M10×1.5P	8	49	434	67	594	80	709
M12×1.75P	10	85	753	116	1028	139	1232
M14×2P	12	137	1214	186	1648	223	1976
M16×2P	14	210	1860	286	2534	343	3038

AATM080AS~~200BS-2AX-□-CR-S□

*2AX:2軸型式

*□:減速比(1/2,1/3),客製品(1/5,1/10)

*S□:S1~S11(入力端尺寸記號)

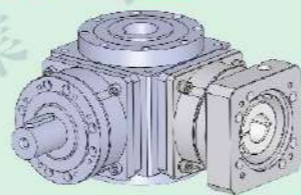

外形尺寸圖 Dimensions:

Unit:mm

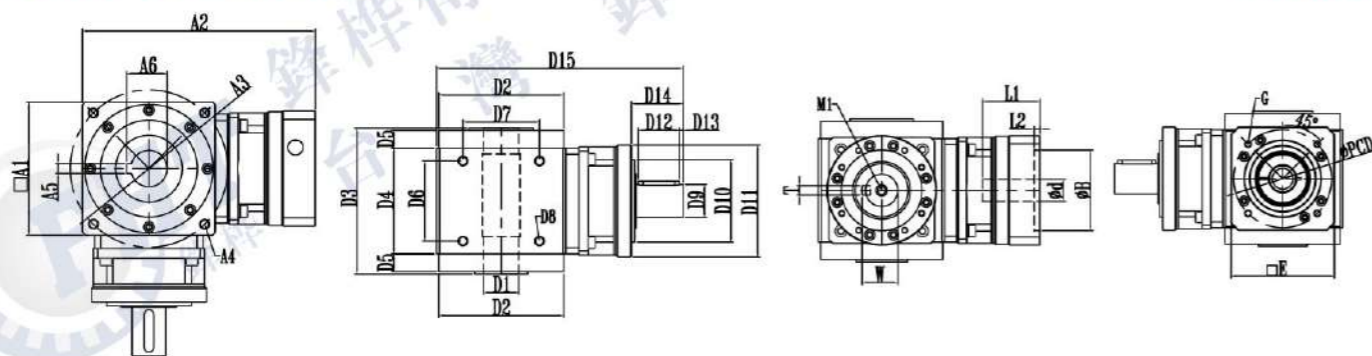

AATM080AS~~200BS-2AX-□-CR-S□:尺寸表

規格	AATM080AS-2AX	AATM110AS-2AX	AATM135AS-2AX	AATM165AS-2AX	AATM200BS-2AX
□A1	80	110	138	168	200
A2	157.7	192.5	244.5	278	312
A3	93	130	160	193	240
A4	4-M6-12L	4-M8-15L	4-M10-18L	4-M12-20L	4-M16-30L
A5	6	8	12	14	16
A6	22.7	33.3	43.3	58.8	74.3
φD1 _{H7}	20	30	40	55	70
φD2 _{H7}	78	106	133	163	195
D3	96	124	146	172	202
D4	67	90	120	142	155
D5	13	15	10	13	22
D6	49.5	68	86	106	129
D7	49.5	65	83	105	130
D8	4-M6-12L	4-M8-15L	4-M10-18L	4-M14-16L	4-M14-25L
φD9 _{H8}	20	28	35	50	50
φD10		70	110	110	110
φD11	62	95	120	142	142
D12	20	35	40	60	60
D13	3	3	3	3	3
D14	32.2	44	51.5	75	75
D15	173.9	209.5	259.5	317	355
T	6	8	12	14	14
W	22.5	31	43.3	53.5	53.5
M1	M6	M8	M10	M12	M12
φd _{H6}	≤19	≤24	≤35	≤42	≤42
φB _{H7}	≤70	≤110	≤114.3	≤180	≤180
L1	≤41	≤60	≤80	≤116	≤116
L2	≤5	≤6	≤6	≤6	≤6
PCD	≤90	≤145	≤200	≤235	≤235
G	≤4-M6	≤4-M8	≤4-M12	≤4-M12	≤4-M12
□E	≤80	≤120	≤176	≤200	≤200

*入力軸與法蘭詳細尺寸C1~C7,如頁數57P

AATM080AS~~200BS-2AX-□-CR-S□

*2AX:2軸型式

*□:減速比(1/2,1/3),客製品(1/5,1/10)

*S□:S1~S11(入力端尺寸記號)

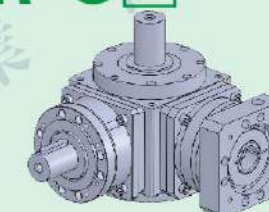

外形尺寸圖 Dimensions:

Unit:mm

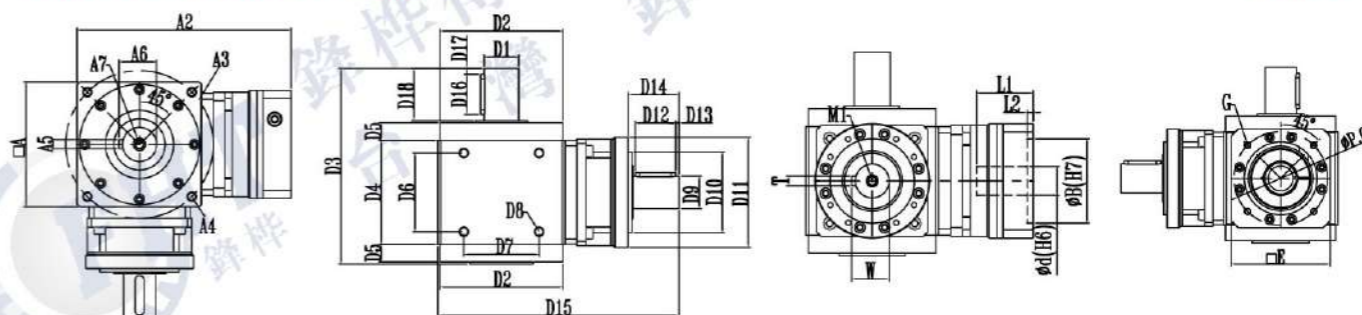

AATM080AS~~200BS-2AX-□-P-S□:尺寸表

規格	AATM080AS-2AX	AATM110AS-2AX	AATM135AS-2AX	AATM165AS-2AX	AATM200BS-2AX
□A1	80	110	138	168	200
A2	157.7	192.5	244.5	278	312
A3	93	130	160	193	240
A4	4-M6-12L	4-M8-15L	4-M10-18L	4-M12-20L	4-M16-30L
A5	6	8	12	16	20
A6	22.5	33	43	59	79.5
φD1 _{H7}	20	30	40	55	75
φD2 _{H7}	78	106	133	163	195
D3	131.5	169	201	252	302
D4	67	90	120	142	155
D5	13	15	10	13	22
D6	49.5	68	86	106	129
D7	49.5	65	83	105	130
D8	4-M6-12L	4-M8-15L	4-M10-18L	4-M14-16L	4-M14-25L
φD9 _{H6}	20	28	35	50	50
φD10		70	110	110	110
φD11	62	95	120	142	142
D12	20	35	40	60	60
D13	3	3	3	3	3
D14	32.2	44	51.5	75	75
D15	173.9	209.5	222	317	355
D16	25	35	45	70	90
D17	2	5	5	3	5
D18	35	45	55	80	100
T	6	8	12	14	14
W	22.5	31	43.3	53.5	53.5
M1	M6	M8	M10	M12	M12
φd _{H6}	≤19	≤24	≤35	≤42	≤42
φB _{H7}	≤70	≤110	≤114.3	≤180	≤180
L1	≤41	≤60	≤80	≤116	≤116
L2	≤5	≤6	≤6	≤6	≤6
PCD	≤90	≤145	≤200	≤235	≤235
G	≤4-M6	≤4-M8	≤4-M12	≤4-M12	≤4-M12
□E	≤80	≤120	≤176	≤200	≤200

*入力軸與法蘭詳細尺寸C1~C7,如頁數57P